

CSI-75K-T40001-E
CSI-100K-T4001A-E
CSI-100K-T4001B-E
CSI-110K-T4001A-E
CSI-110K-T4001B-E
CSI-120K-T4001A-E
CSI-120K-T4001B-E

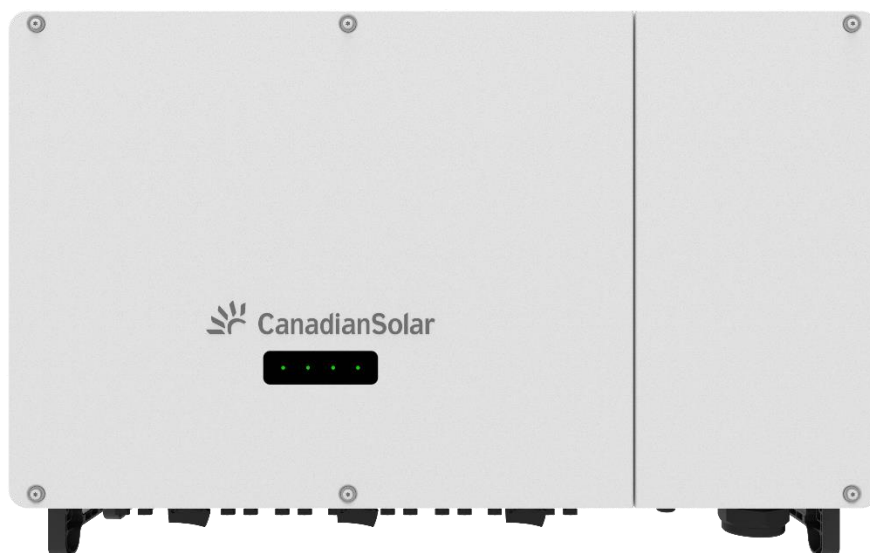

PV Inverter Quick Installation Guide

(Part No: 91000396; Release Date: December, 2023)

1. About This Guide

- 1) This guide only applies to the following inverters: CSI-75K-T40001-E*, CSI-100K-T4001A-E, CSI-100K-T4001B-E, CSI-110K-T4001A-E, CSI-110K-T4001B-E, CSI-120K-T4001A-E and CSI-120K-T4001B-E.
 - 2) This instruction only provides an overview of the installation of the above-mentioned inverters.
 - 3) Due to product version upgrades or other reasons, this guidance will be updated irregularly. Under no circumstances can this guide replace the user manual and the safety instructions on the product.
 - 4) Please read the user manual and related standard specifications carefully before performing any operation on this series of products. You can scan the QR code on the left side of the device or at the end of this guide to obtain an electronic copy of the manual.
 - 5) All operations on this series of products must be completed by professional technicians. Professional and technical personnel must be specially trained, read the user manual, master the safety matters related to the operation, and be familiar with local standards and electrical system safety specifications.
 - 6) Before installing the products, please check whether the products are complete, consistent with the order, and whether there is obvious damage. If there is any abnormality, please contact the local dealer or CSI Solar Co., Ltd.
- *This product is not available for the EMEA market now.

2 Product Introduction

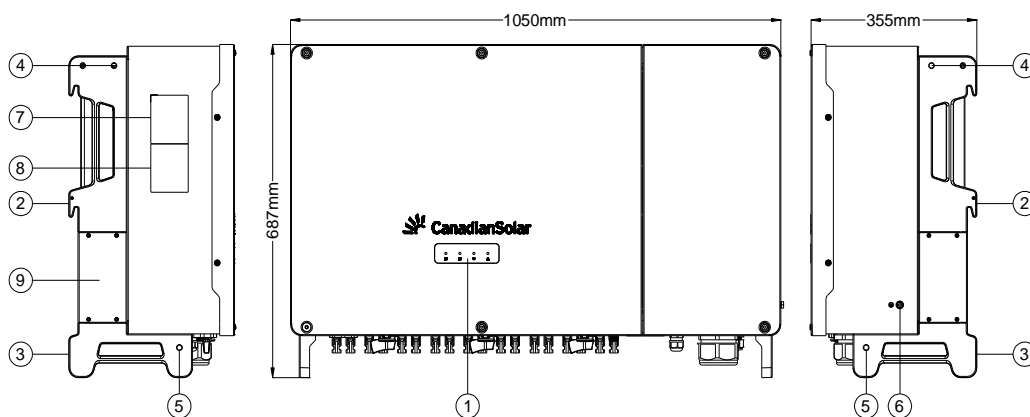

CSI-75K-T40001-E
 CSI-100K-T4001A-E
 CSI-110K-T4001A-E
 CSI-120K-T4001A-E

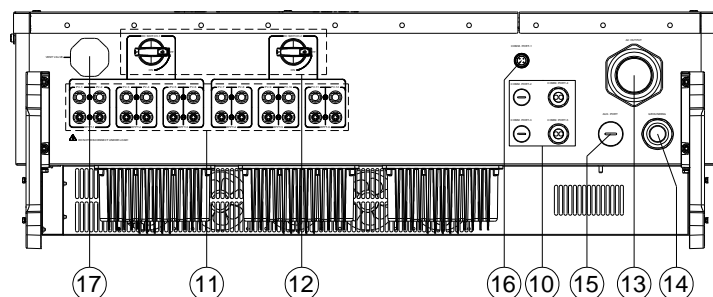

CSI-100K-T4001B-E
 CSI-110K-T4001B-E
 CSI-120K-T4001B-E

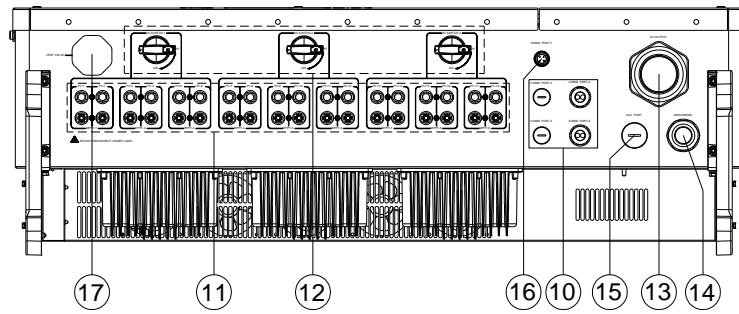

- | | |
|---|---|
| 1. LED indicator panel | 10. Communication cable gland |
| 2. Side handles and mounting supports | 11. PV input connectors |
| 3. Lower mounting supports | 12. DC disconnect switch |
| 4. M12 holes for lifting eyes or shanks | 13. AC output cable gland |
| 5. M12 holes for lifting shanks | 14. Interior grounding cable gland |
| 6. Additional grounding points | 15. Reserved auxiliary port |
| 7. Nameplate | 16. Communication connector for data logger |
| 8. Warning label | 17. Breather valve |
| 9. The cover of the outer fan module | |

FIG 2-1 Product introduction (The picture is for reference only)

3.1 Installation Environment Requirements

- 1) Do not install the inverter on structures constructed of flammable, thermolabile, or explosive materials.
- 2) Ensure the inverter is out of children's reach.
- 3) The ambient temperature should be between -30°C~ 60°C.
- 4) The humidity of the installation location should be below 100% without condensation.
- 5) Do not install the inverter outdoors in salt, sulfur, or other corrosive areas.
- 6) Prevent the inverter from direct exposure to sun, rain and snow.
- 7) The inverter should be well-ventilated. Ensure air circulation.
- 8) Never install the inverter in living areas. The inverter will generate noise during operation, affecting daily life.
- 9) Install at an appropriate height for ease of viewing LED indicators and operating switches.

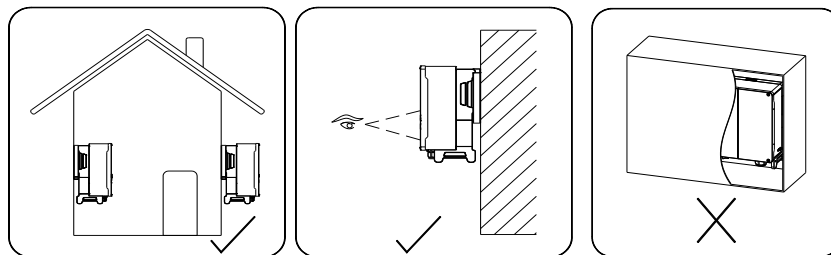

FIG 3-1 Installation site

3.2 Structural Requirements

The inverter(s) must be installed on a structure with a load-bearing capacity of >4 times the inverter weight.

3.3 Installation Angle Requirements

Install the inverter vertically or at a minimum back tilt of 10°. Forward installation or upside-down installation is prohibited.

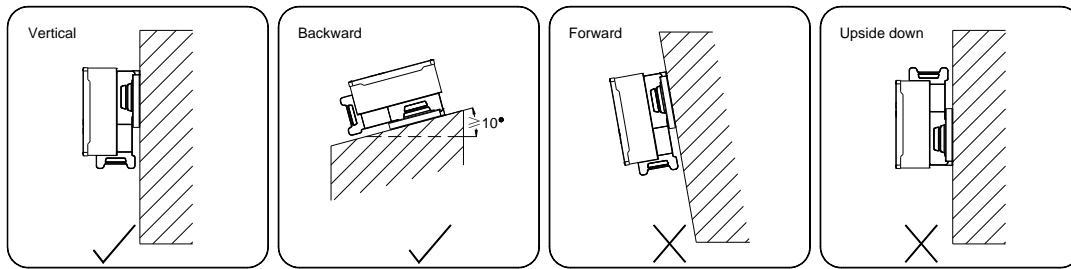

FIG 3-2 Installation angle

3.4 Installation Clearance Requirements

- 1) Reserve enough clearance around the inverter to ensure sufficient space for heat dissipation. (3-3 The maintenance of the inverter's external fan module requires a larger clearance on the left side).
- 2) In case of multiple inverters, reserve specific clearance between the inverters. 3-4

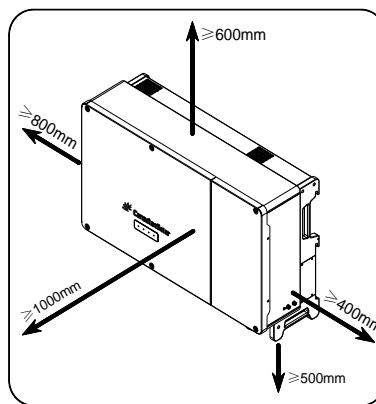

FIG 3-3 Single inverter installation space

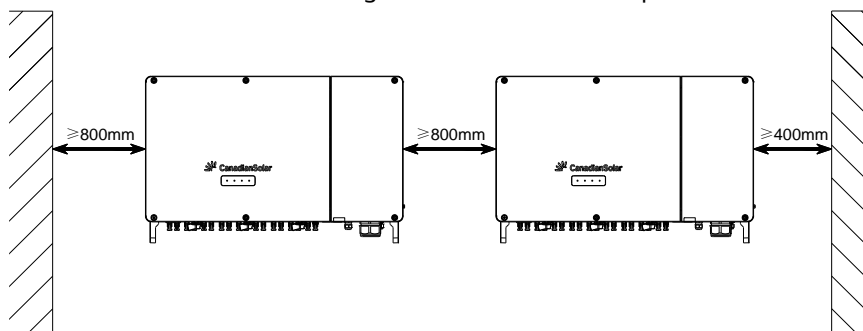

FIG 3-4 Multiple inverters installation space

3.5 Assembling the mounting-bracket

Dimensions of the assembled mounting bracket are as follows 3-5.

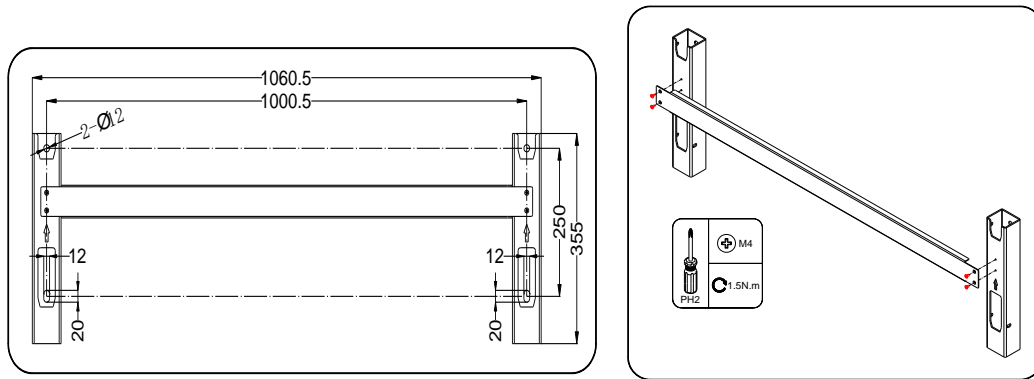

FIG 3-5 Assembly mounting bracket

3.5.1 Standard C or U Steel Installation

Mounting Steps:

Step 1: Localize the hole positions in C or U-section steel to install the mounting bracket.

Step 2: Secure the mounting bracket with M10 bolts and nuts.

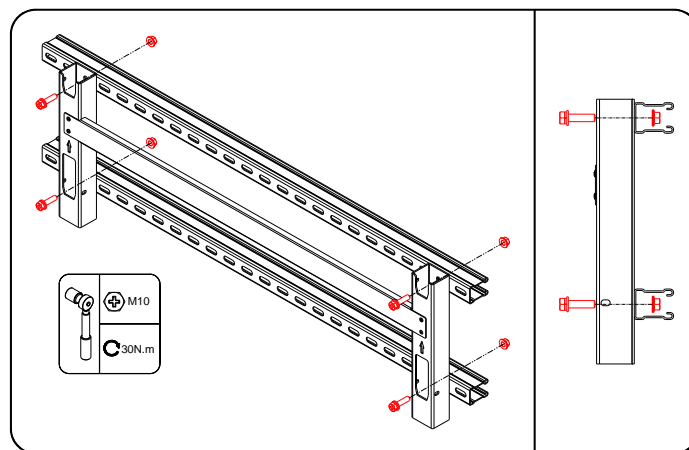

FIG 3-6 Locate the mounting hole

3.5.2 Steel Frame Installation

Mounting Steps:

Step 1: Level the assembled mounting bracket by using a level, and mark the positions for drilling holes on the steel frame.

Drill the holes. Recommended aperture 12mm.

Step 2: Secure the mounting bracket with M10 bolts and nuts.

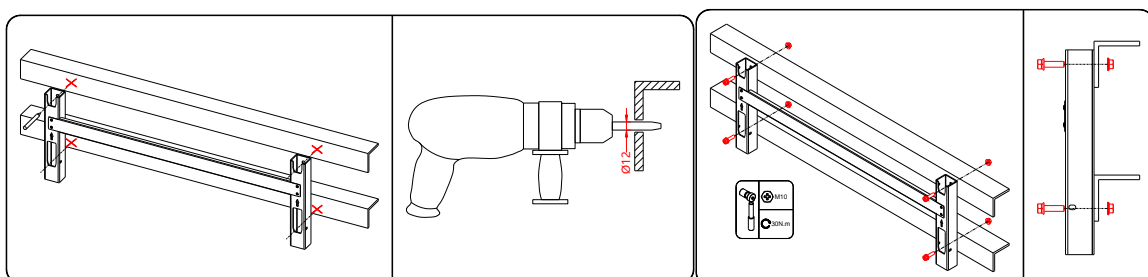

FIG 3-7 Install the wall bracket

3.6 Inverter Installation

Step 1: Take out the inverter from the packing carton.

Step 2: Hoist the inverter to the installation position.

Step 3: Hang the inverter to the mounting bracket and ensure that the mounting ears perfectly engage with the mounting bracket.

Step 4: Fix the inverter with screws M6x30.

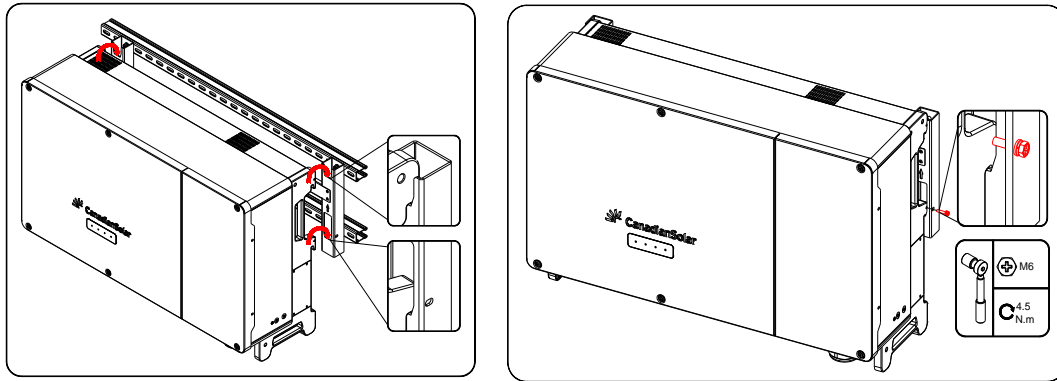

FIG 3-8 Install the inverter

4 Electrical Connection

4.1 Electrical Connection Overview

A) PV string; B) Inverter; C) AC distribution box/cabinet; D) Utility grid; E) Monitoring device

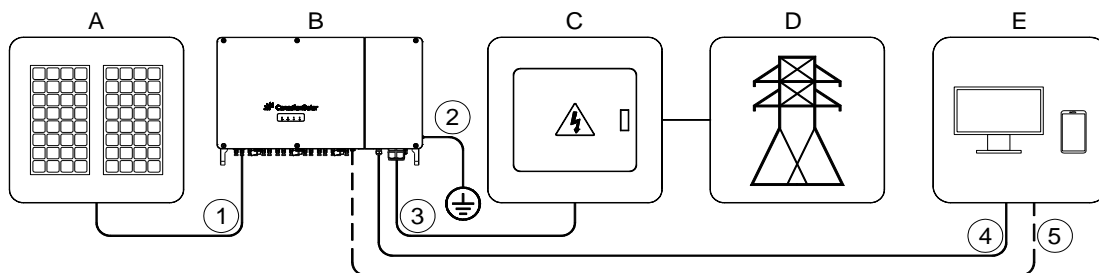

FIG 4-1 General electrical connection diagram

Table 4-1 Recommended Cables

No.	Cable Name	Cable Type	Conductor Cross-Sectional Area	Outer Diameter
1	DC cable	PV cable (Rec. type: PV1-F or H1Z2Z2-K)	4 or 6mm ² (Max.)	6~9mm
2	Additional Grounding cable	Outdoor single core copper conductor cable	Refer to "table 5-2 PE wire requirements"	
3	AC cable	Four-core outdoor copper or aluminum cables* (Recommended)	1) 75KW: 4 x 50~185 mm ² 75KW: 3 x 240+1 x 120mm ² 2) 100~120KW: 4 x 70~185 mm ² 100~120KW: 3 x 240+1 x 120mm ²	26~57mm
			PE wire: refer to "table 5-2 PE wire requirements"	
		Five-core outdoor copper or aluminum cables*	1) 75KW: 5 x 50~185 mm ² 2) 100~120KW: 5 x 70~185 mm ²	26~57mm
		Single-core outdoor copper or aluminum cables*	Phase wire and N wire: 1) 75Kw: 50~120 mm ² 2) 100~120Kw: 70~120 mm ²	12~22mm
		PE wire: refer to "table 5-2 PE wire requirements"		
4	Communication cable	Shielded twisted pair (terminal block)	0.25~1.0 mm ²	4~6mm
		CAT-5 Ethernet cable (RJ45)	N/A	
5	Wireless communication	N/A	N/A	N/A

* A copper to aluminum adapter terminal is required when an aluminum cable is used.

Table 4-2 PE wire requirements

Phase wire cross section S	PE wire cross-section	Outer Diameter	Note
S > 35 mm ²	S/2	12~25mm	The specifications are valid only when the phase and PE wires use the same material. If otherwise, ensure that the cross-section of PE wire produces a conductance equivalent to that of the wire specified in the table.

Table 4-3 Power cable for tracking system

Cable	Cable Type	Conductor Cross-Sectional Area	Outer Diameter	Voltage Level
Power cable for tracking system	Outdoor copper conductor cable	2 or 3 x 4~10mm ²	12~25mm	Consistent with selected AC cable

4.2 Connecting the PE Cable

 WARNING	<p>Since the inverter is a transformerless inverter, neither the negative pole nor the positive pole of the PV string can be grounded. Otherwise, the inverter will not operate normally.</p> <p>Connect the additional grounding terminal to the protective grounding point before AC, PV, and communication cable connections.</p> <p>The ground connection of this additional grounding terminal cannot replace the connection of the PE terminal of the AC cable. Make sure those terminals are both grounded reliably.</p>
---	---

4.2.1 Additional Grounding Requirements

All non-current carrying metal parts and device enclosures in the PV power system should be grounded, for example, brackets of PV modules and inverter enclosure. When there is only one inverter in the PV system, connect the additional grounding cable to a nearby grounding point.

When there are multiple inverters in the PV system, connect grounding points of all inverters and the PV array frames to the equipotential cable (according to the onsite conditions) to implement an equipotential connection.

4.2.2 Connection Procedure

Step 1: Prepare the cable and terminal.

Step 2: Remove the screw on the grounding terminal and fasten the cable with a wrench.

Step 3: Apply paint to the grounding terminal to ensure corrosion resistance.

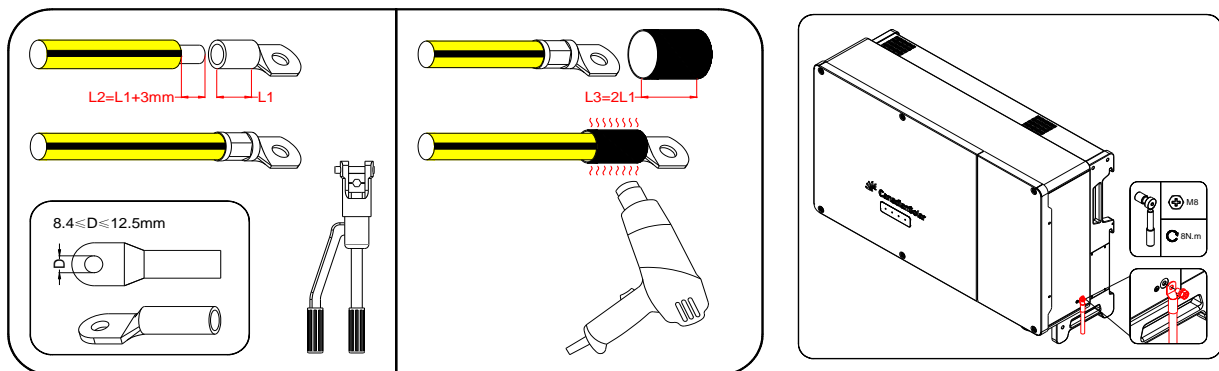

FIG 4-2 PE cable installation

	<p>The grounding screws have been anchored to the side of the inverter before delivery, and do not need to be prepared.</p>
--	---

4.3 Communication Cable Connection

4.3.1 Opening the Wiring Compartment

Step 1: Loosen four screws on the front cover of the wiring compartment with screwdriver T30.

Step 2: Open the wiring compartment.

Step 3: Loosen the screws on the communication protection cover, and remove the protection cover.

Note: Close the wiring compartment in reverse order after completing wiring operations.

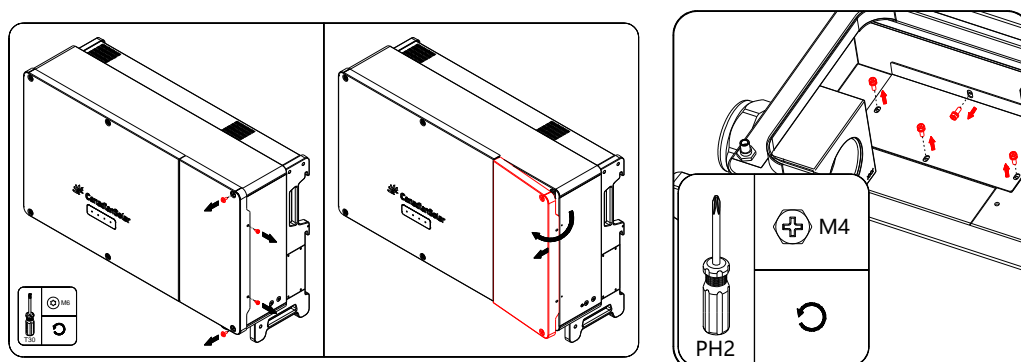

FIG 4-3 Open the Wiring Compartment

4.3.2 Communications Interface Description

FIG 4-4 shows the position of the communication wiring board in the inverter and the terminals of this board.

4.3.3 RS485 Communication

The inverter has an RS485 communication port with 4 connectors (RS485-1, RS485-2, RS485-3, and RS485-4) for external communication connection.

The terminal blocks (RS485-1 and RS485-2) and RJ45 connectors (RS485-3 and RS485-4) all have the same functionality. Select either port for cable connection.

4.3.3.1 Single-inverter communication system

In the case of a single inverter, select either the terminal block interface (RS485-1 or RS485-2) or RJ45 interface (RS485-3 or RS485-4).

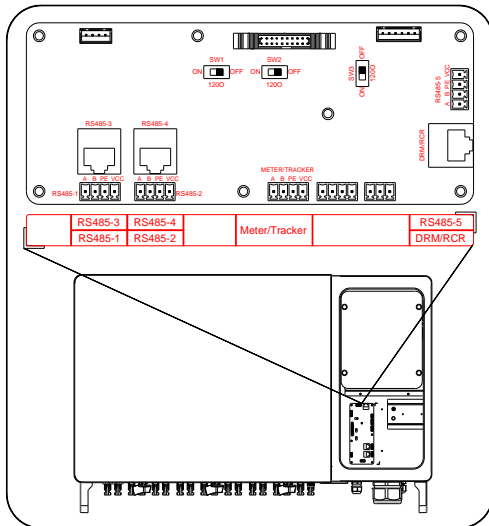

FIG 4-4 Communications interface description

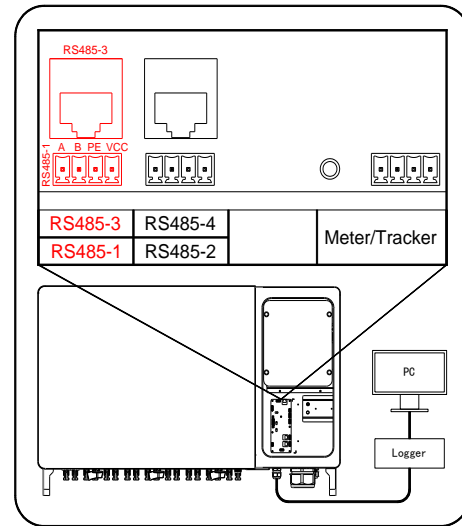

FIG 4-5 Single-inverter communication system

4.3.3.2 Multi-inverter communication system

In case of multiple inverters, select either terminal block interface or RJ45 interface to connect.

1) All the inverters are connected via terminal block interface (RS485 cables) in the daisy chain.

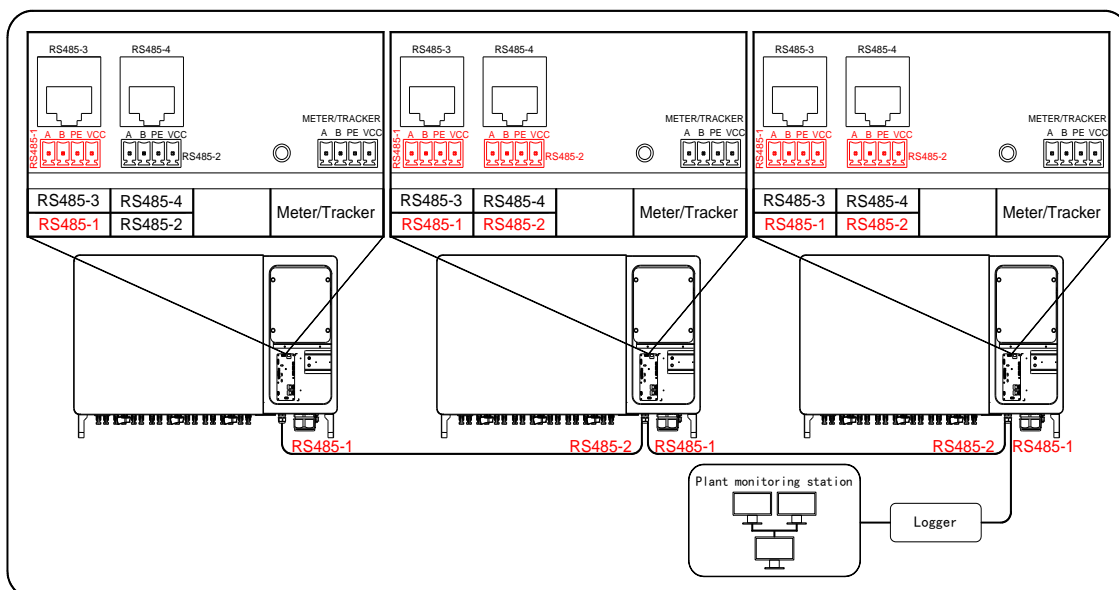

FIG 4-6 Multi-inverter communication system using terminals

2) All the inverters are connected via RJ45 interface (internet cable) in the daisy chain.

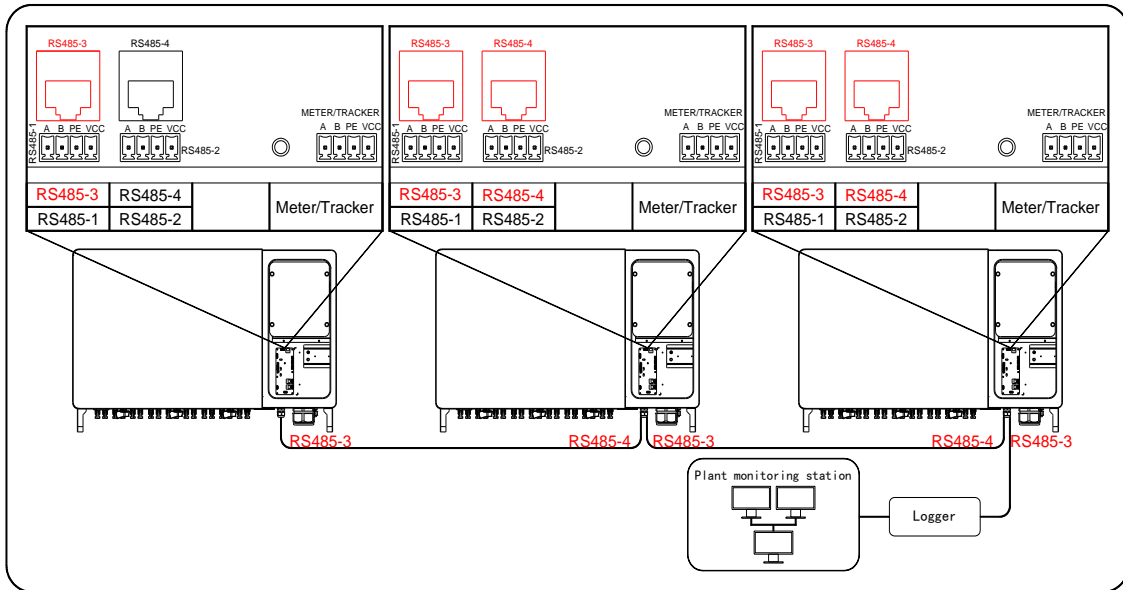

FIG 4-7 Multi-inverter communication system using RJ45 connectors

3) More than 15 inverters communication.

All the inverters are connected via the terminal block interface in the daisy chain.

When more than 15 inverters are connected on the same daisy chain, the communication line on both ends should be terminated with 120Ω resistors to ensure communication quality. This can be achieved by configuring the dip switch (SW2).

The shielding layer of the communication cable should be single-point grounded.

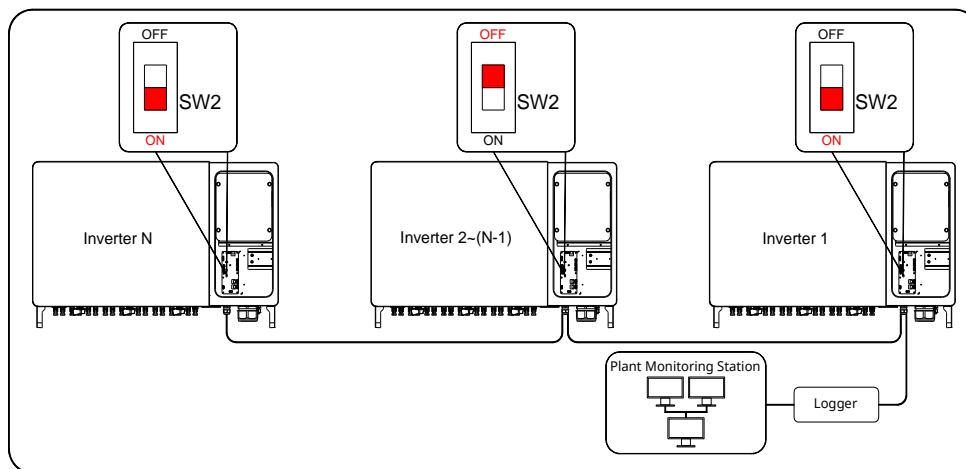

FIG 4-8 More than 15 inverters communication system

4.3.3.3 Connection Procedure (Terminal Block)

Step 1: Strip the cable protection layer and wire insulation layer by the appropriate length.

Step 2: Loosen the swivel nut of the communication cable gland and select an appropriate seal according to cable outer diameter. Lead the cable through the swivel nut and seal successively.

Step 3: Secure the cable to the terminal base.

Step 4: Insert the terminal base into the corresponding terminal.

Step 5: Pull the cable gently to ensure it is secured, and tighten the swivel nut clockwise.

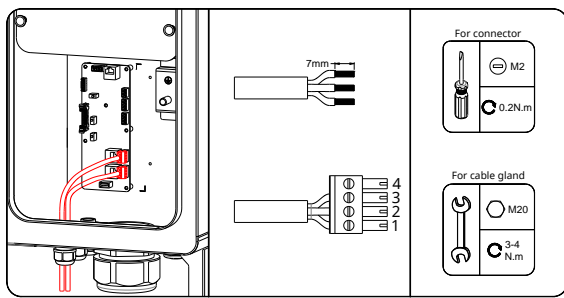

Connector	Function	Connecting the communication board
Pin-1	485-A	A1
Pin-2	485-B	B1
Pin-3	grounding (shielding layer of cables)	PE

FIG 4-9 Connection Procedure (Terminal Block)

4.3.3.4 Connection Procedure (RJ45 network port)

Step 1: Loosen the swivel nut of the communication terminal and select an appropriate seal according to cable outer diameter. Lead the cable through the swivel nut and seal successively.

Step 2: Strip the insulation layer of the Ethernet cable with a wire stripper, and insert the signal wires to the RJ45 connector. Crimp the RJ45 connector with a crimping tool.

Step 3: Insert the RJ45 connector to the RJ45 jack.

Step 4: Pull the cable gently to make sure it is secured, tighten the swivel nut clockwise.

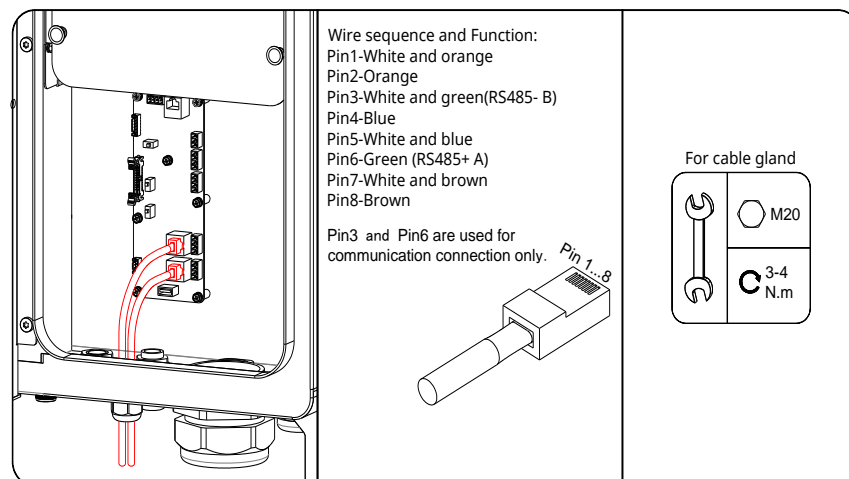

FIG 4-10 Connection Procedure (RJ45 network port)

4.4 Dongle Connection

This product supports Dongle Connection. For more information about the data logger, please refer to the Smart Data Logger (WIFI) Quick Installation Guide.

4.5 AC Cable Connection

4.5.1 AC Side Requirements

Before connecting the inverter to the grid, ensure the grid voltage and frequency comply with inverter(s) technical specification. Otherwise, contact the electric power company for help.

	Connect the inverter to the grid only after getting an approval from the local electric power company.
---	--

4.5.2 Connection Procedure

Step 1: Open the wiring compartment.

Step 2: Pull out four plastic rivets on the protection plate, then remove the protection plate.

Step 3: Disconnect the AC-side circuit breaker and prevent it from inadvertent reconnection.

Step 4: Loosen the swivel nut of the AC waterproof connector and select a seal rings according to the cable outer diameter.
Lead the cable through the swivel nut, seal rings, and wiring terminal successively.

Step 5: Strip the protection layer and insulation layer by specific length, as described in the figure below.

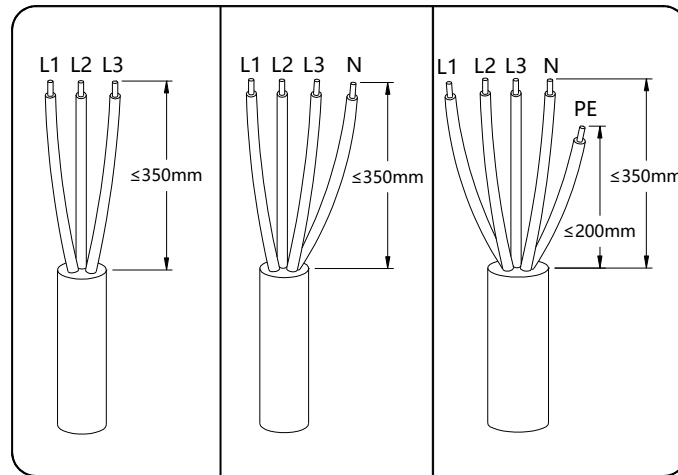

FIG 4-12 AC cable stripping requirements

Step 6: Crimp the cable shoes.

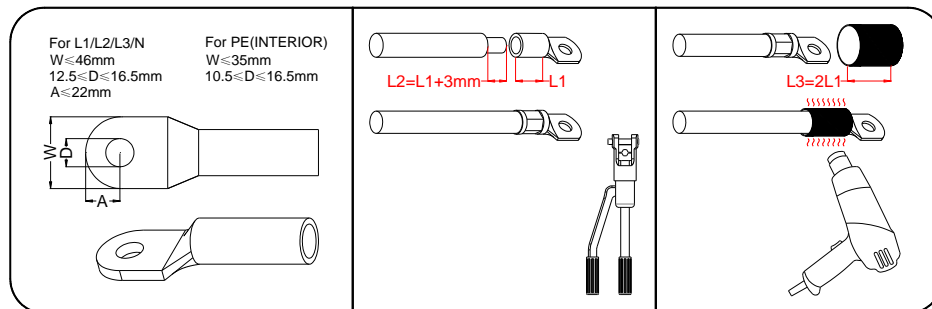

FIG 4-13 Prepare the cable

* Please purchase crimp terminals yourself.

Step 7: Secure the wires to the corresponding terminals.

Step 8: Gently pull the cable backward to ensure a firm connection, and fasten the swivel nut clockwise.

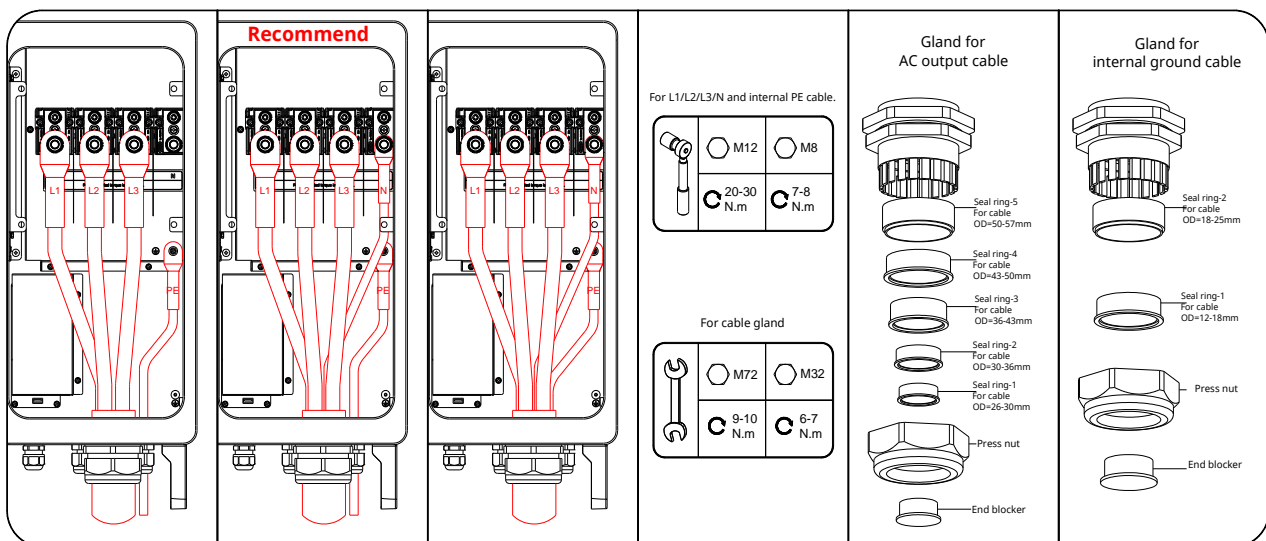

FIG 4-14 Recommended AC cable connection position

NOTE: The AC cable should enter the box vertically, and the length of the straight section should not be less than 200mm.

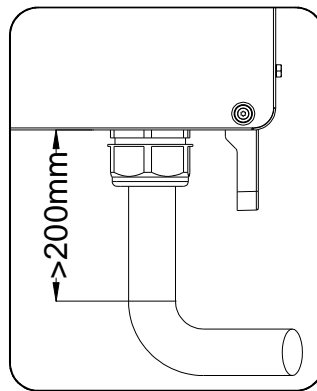

FIG 4-15 AC wiring outlet requirements

4.5.3 Closing the Wiring Compartment

Step 1: Attach the protection plate and push the four plastic rivets into the holes in the chassis.

Step 2: Close the wiring compartment and tighten the four screws on its front cover with screwdriver T30.

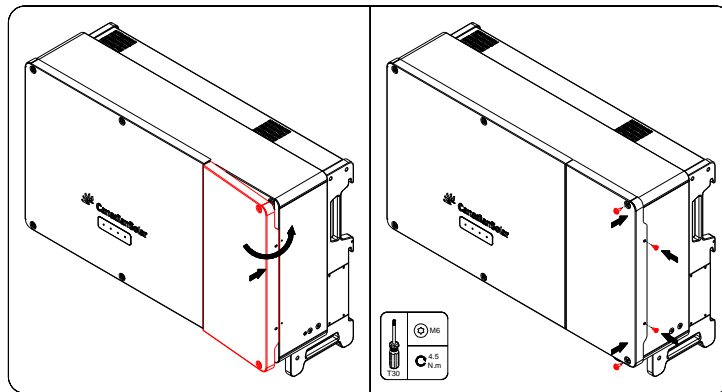





FIG 4-15 Close the wiring compartment

Notice: The gap between AC cable and waterproof gland must be blocked with fireproof mud to prevent water or moisture.

4.6 DC Cable Connection

 DANGER	<p>Electric shock! The PV array will generate lethal high voltage once exposed to sunlight. Before performing electrical operations, ensure that all cables are uncharged. Do not turn on the AC circuit breaker before the inverter is electrically connected.</p>
 CAUTION	<p>Make sure the PV array is well insulated to the ground before connecting it to the inverter. During the installation of PV strings and the solar inverter, the positive or negative terminals of PV strings may be short-circuited to ground if the power cable is not properly installed or routed. In this case, an AC or DC short circuit may occur and damage the solar inverter. In the event of an AC or DC short circuit causing damage to the solar inverter, please note that the affected device is not covered under any warranty.</p>
 NOTICE	<p>There is a risk of inverter damage! The following requirements should be met. Failure to do so will void guarantee and warranty claims.</p> <ul style="list-style-type: none"> • Make sure the maximum voltage of each string is always less than 1100 V. • The inverter enters the standby state when the input voltage ranges between 1,000V and 1,100V. The inverter returns to the running state once the voltage returns to the MPPT operating voltage range (200 to 1,000V). <p>Make sure the maximum short circuit current on the DC side is within the permissible range.</p>

	<ul style="list-style-type: none"> The polarities of electric connections are correct on the DC input side. The positive and negative terminals of the PV string are connected to the corresponding positive and negative DC input terminals of the solar inverter.
	<p>Use the connectors delivered with the solar inverter. If the PV connectors are lost or damaged, purchase the connectors of the same model. The device damage caused by incompatible PV connectors is beyond the warranty scope.</p>

4.6.1 Connection Procedure

Step 1: Strip the insulation from each DC cable by 7mm.

Step 2: Assemble the cable ends with the crimping pliers

Step 3: Lead the cable through cable gland, and insert into the insulator until it snaps into place.

Gently pull the cable backward to ensure firm connection. Tighten the cable gland and the insulator (torque 2.5 N.m to 3 N.m).

Step 4: Check for polarity correctness.

The inverter will not function properly if any PV polarity is reversed.

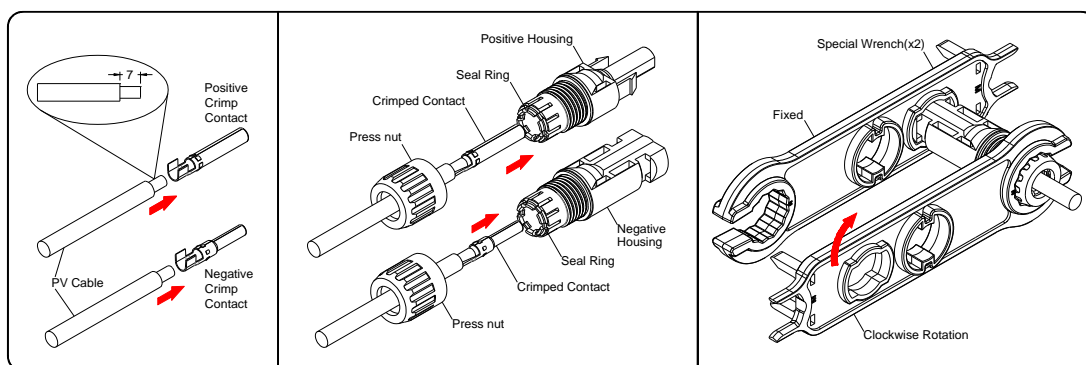

FIG 4-16 DC cable connection

4.6.2 Installing the PV Connectors

Step 1: Rotate all the DC switches to "OFF" position.

Step 2: Check the cable connection of the PV string for polarity correctness and ensure that the open circuit voltage in any case does not exceed the inverter input limit of 1,100V.

Step 3: Connect the PV connectors to corresponding terminals until there is an audible click.

Step 4: Follow the foregoing steps to connect PV connectors of other PV strings.

Step 5: Seal the unused PV terminals with the terminal caps.

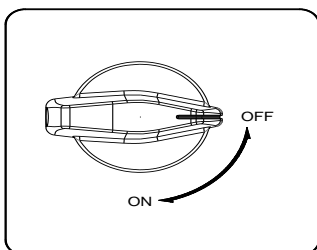

FIG 4-17 DC switch

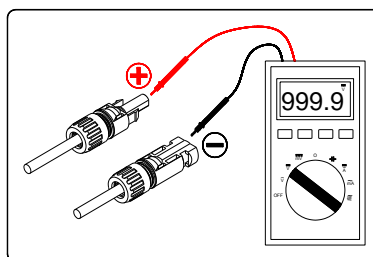

FIG 4-18 Check the polarity of PV string

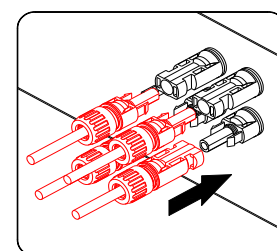

FIG 4-19 Connect the PV connectors to the inverter

5 Commissioning Inverter

5.1 Electrical Inspection

Table 5-1 Inspection before Commissioning

No.	Inspection Items	Result	
		Yes	No
1	The inverter DC switch and external circuit breaker are disconnected		
2	The inverter should be accessible for operation, maintenance and service.		
3	Nothing is left on the top of the inverter.		
4	The inverter is correctly connected to the external devices.		
5	The cables are routed in a safe place or protected against mechanical damage.		
6	The selection of the AC circuit breaker is in accordance with the User manual and all applicable local standards.		
7	All unused terminals at the bottom of the inverter are properly sealed.		
8	Warning signs & labels are suitably affixed and durable.		

5.2 Commissioning Procedure

If all of the items mentioned above meet the requirements, proceed as follows to start up the inverter for the first time.



Step 1: Rotate the DC switch of the inverter to "ON" position.

Step 2: Connect the AC switch (if applicable) between the inverter and the grid.

Step 3: Connect the DC switch (if applicable) between the inverter and the PV string.

Step 4: Set initial protection parameters via the CSI Cloud App. If the irradiation and grid conditions meet requirements, the inverter will normally operate.

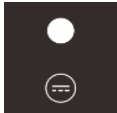
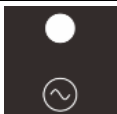
Step 5: Observe the LED indicator to ensure that the inverter operates normally.

LED indicator	LED state	Definition
 PV connection indicator	Steady green	At least one PV string is properly connected, and the DC input voltage of the corresponding MPPT circuit is at least 200V.
	Off	The solar inverter disconnects from all PV strings, or the DC input voltage of all MPPT circuits is less than 200V.
 Grid connection indicator	Steady green	The solar inverter is in grid-tied mode.
	Blinking green	The solar inverter is in self-test mode or wait mode.
	Off	The solar inverter is not in grid-tied mode.
 Communications/Maintenance indicator	Blinking green	The solar inverter receives communication data normally
	Off	The solar inverter has not receives communication data for 10 seconds.
	Steady green	The solar inverter is in maintenance status
 Alarm indicator	Steady red	A major alarm is generated.
	Blinking red	A minor or warning alarm is generated.
	Off	No alarm

6 CSI Smart Energy App - Local Mode

6.1 APP Introduction

The CSI SmartEnergy APP can establish a communication connection to the dongle via Bluetooth, thereby achieving local access to the inverter. Users can use the App to view basic information, alarms, set parameters, etc.

6.2 Download and Install the App

Method 1 Scan the following QR Code to download and install the App according to the prompt information.



Method 2: For the monitoring and local APP information, please refer to documents published on our website:
<https://smartenergy.csisolar.com>

6.3 Use the Local Mode to login the App

Notice: To use the local mode, the following conditions should be met:

- (1) The dongle is connected to the inverter and powered on.
- (2) The distance between the mobile phone and the dongle should be within 5m and there are no obstacles.
- (3) Make sure the Bluetooth of your phone is turned on.

Step 1: Open the CSI SmartEnergy APP.

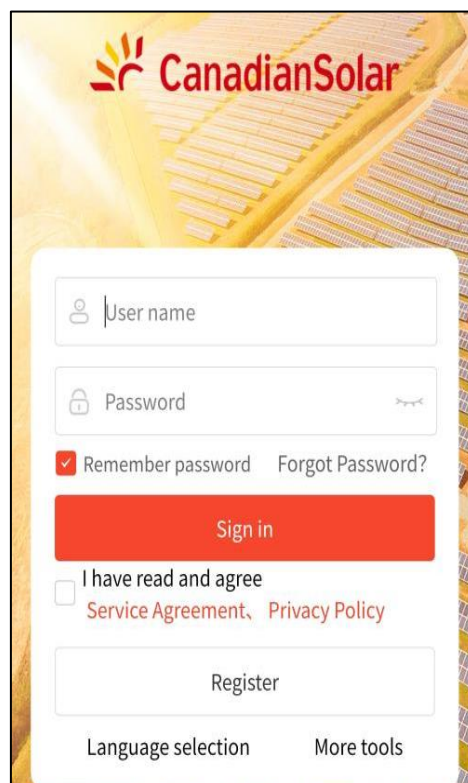

Step 2: Select " More tools"->" Local Access". Scan the QR code of the dongle, and the mobile phone will connect the dongle automatically.

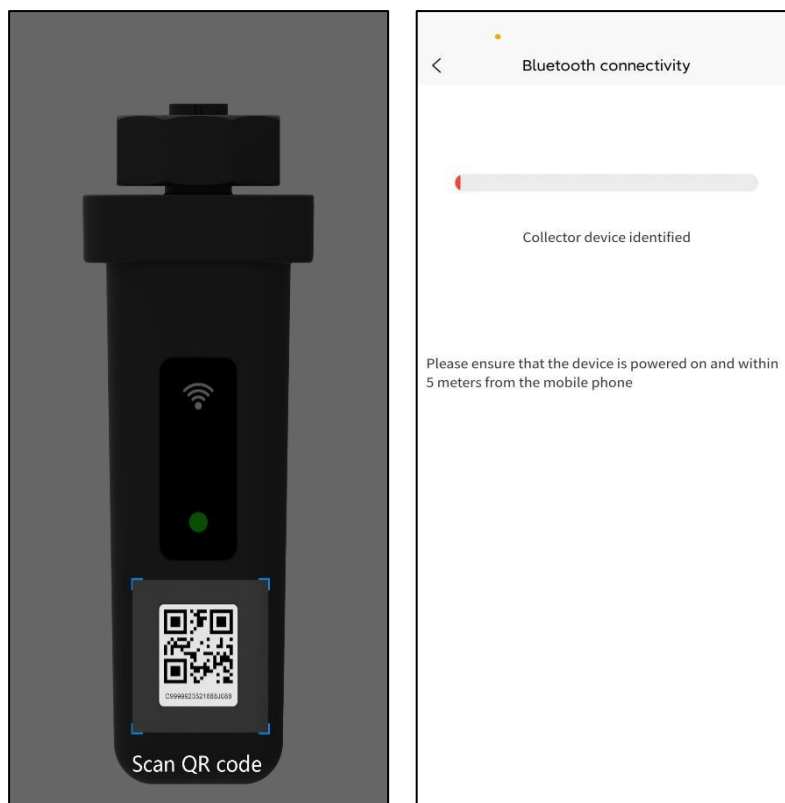

Step 3: If the inverter is booted for the first time, you need to set the Grid Code as required on the boot page.

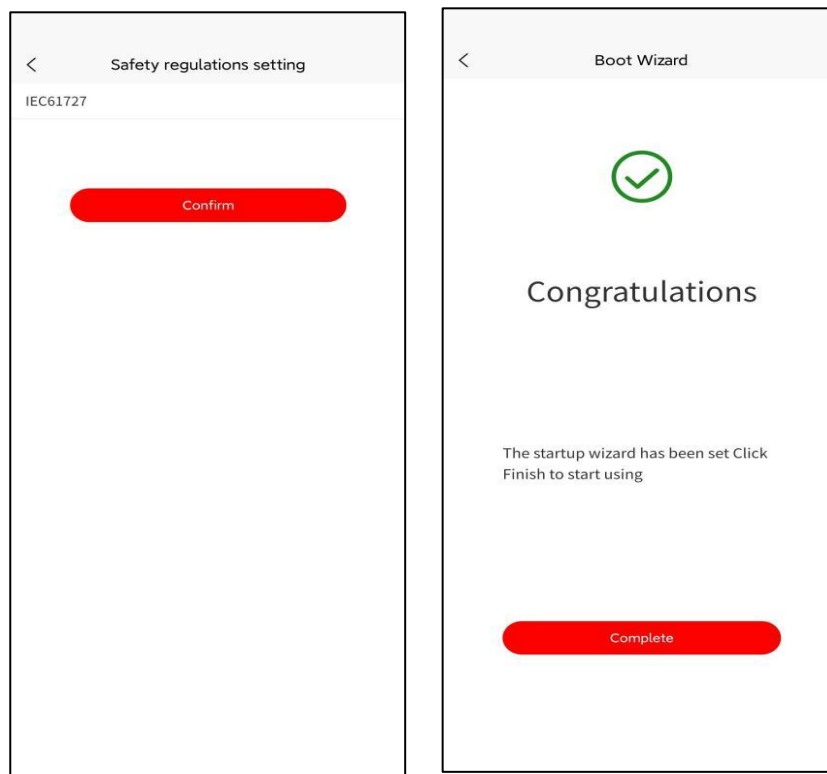
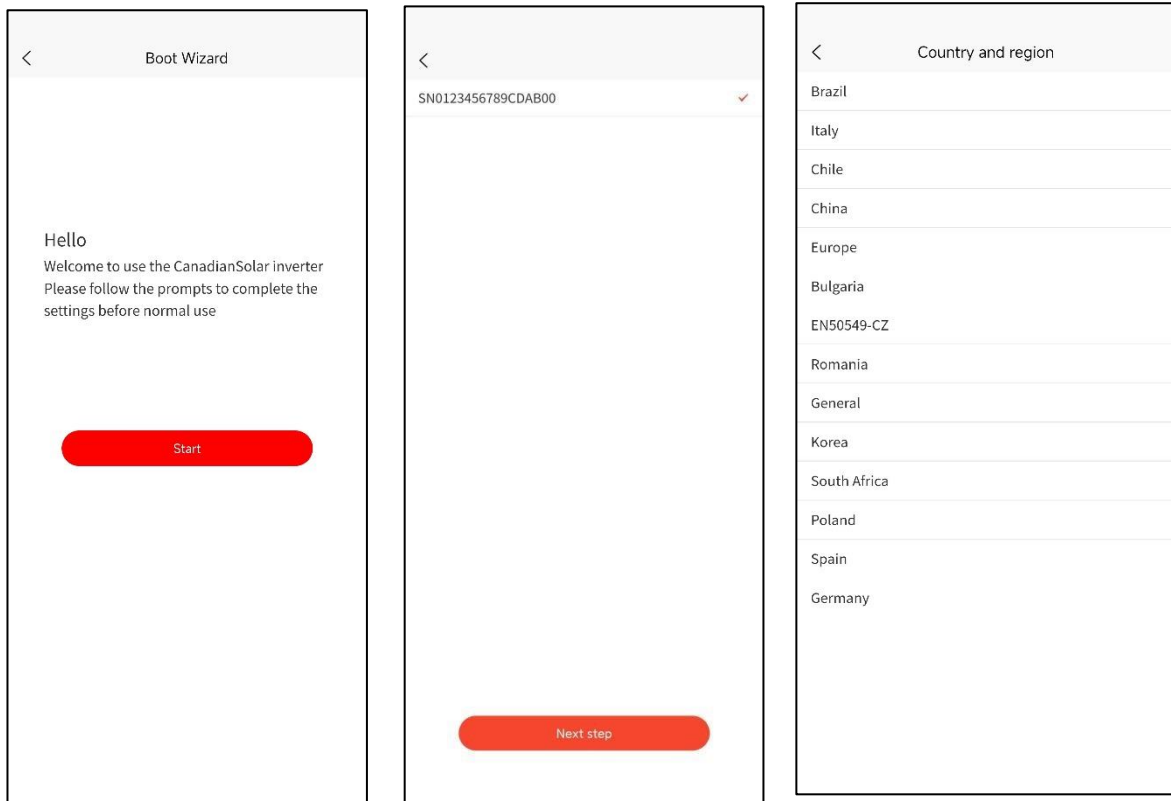
Notice

Must select the correct grid code where the inverter is installed. If the grid code is not suitable, it may cause the inverter to report a fault error.

You can also set the grid code on the "Parameter" -> "Inverter Basic Information-DSP" -> "Grid Code" after setting on this page.

6.4 Function List

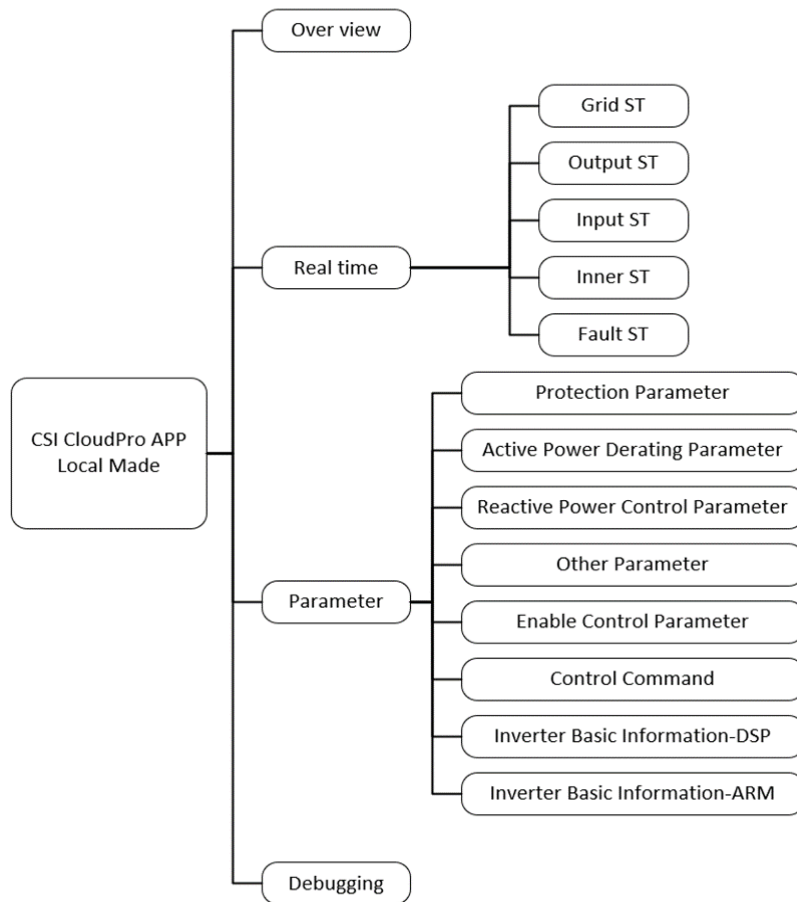

7 Obtaining User Manual

Please scan the QR code for more detailed information in the user manual.

