



CANADIAN SOLAR INC.

Global Headquarters:

545 Speedvale Avenue, West Guelph, Ontario N1K 1E6, Canada

Tel: +1 519 837 1881

Sales Inquiries Email: sales.ca@canadiansolar.com

Technical Inquiries Email: service.ca@canadiansolar.com

CANADIAN SOLAR (USA), INC.

North America Headquarters:

3000 Oak Road, Ste 400, Walnut Creek, CA 94596

Tel: +1 888 998 7739

Sales Inquiries Email: sales.us@canadiansolar.com

Technical Inquiries Email: service.ca@canadiansolar.com

CANADIAN SOLAR (EMEA) INC.

EMEA Headquarters:

Canadian Solar EMEA GmbH, Landsberger Str. 94, D-80339 Munich / Germany

Tel: +49 89 5199 689 0

Sales Inquiries Email: sales.emea@canadiansolar.com

Technical Inquiries Email: service.emea@canadiansolar.com

This manual is subject to change without prior notification. Copyright is reserved. Duplication of any part of this issue is prohibited without written permission.

CSI SERIES GRID-TIED PV Inverter CSI-4KTL1P-GI & CSI-5KTL1P-GI INSTALLATION AND OPERATION MANUAL VERSION 1.0



Contents

| | |
|---|----|
| 1. Introduction | 3 |
| 1.1 Product Description | 3 |
| 1.2 Packaging | 4 |
| 2. Safety Instructions | 5 |
| 2.1 Safety Symbols | 5 |
| 2.2 General Safety Instructions | 5 |
| 2.3 Notice For Use | 6 |
| 3. Overview | 7 |
| 3.1 Front Panel Display | 7 |
| 3.2 LED Status Indicator Lights | 7 |
| 3.3 Keypad | 8 |
| 3.4 LCD | 8 |
| 4. Installation | 9 |
| 4.1 Select Location for the Inverter | 9 |
| 4.2 Mounting the Inverter | 11 |
| 4.3 Electrical Connections | 13 |
| 4.3.1 Connect PV side of inverter | 13 |
| 4.3.2 Connect grid side of inverter | 16 |
| 4.3.3 External ground connection | 18 |
| 4.3.4 Max. overcurrent protection device (OCPD) | 19 |
| 4.3.5 Inverter monitoring connection | 19 |
| 4.3.6 Electrical connection diagram | 20 |
| 4.3.7 Meter Connection (optional) | 20 |
| 4.3.8 CT connections (optional) | 21 |
| 4.3.9 Logic interface connection (Only for UK) | 22 |
| 5. Start & Stop | 23 |
| 5.1 Start the Inverter | 23 |
| 5.2 Stop the Inverter | 23 |
| 6. Operation | 24 |
| 6.1 Main Menu | 24 |
| 6.2 Information | 24 |
| 6.2.1 Lock screen | 26 |

Contents

| | |
|--|----|
| 6.3 Settings | 26 |
| 6.3.1 Set Time | 26 |
| 6.3.2 Set Address | 26 |
| 6.4 Advanced Info. | 27 |
| 6.4.1 Alarm Message | 27 |
| 6.4.2 Running Message | 28 |
| 6.4.3 Version | 28 |
| 6.4.4 Daily Energy | 28 |
| 6.4.5 Monthly Energy and Yearly Energy | 28 |
| 6.4.6 Daily Record | 29 |
| 6.4.7 Communication Data | 29 |
| 6.4.8 Warning Message | 29 |
| 6.5 Advanced Settings | 29 |
| 6.5.1 Select Standard | 30 |
| 6.5.2 Grid ON/OFF | 31 |
| 6.5.3 Clear Energy | 31 |
| 6.5.4 Reset Password | 31 |
| 6.5.5 Power Control | 31 |
| 6.5.6 Calibrate Energy | 32 |
| 6.5.7 Special Settings | 32 |
| 6.5.8 STD. Mode Settings | 32 |
| 6.5.9 Restore Settings | 33 |
| 6.5.10 HMI Update | 33 |
| 6.5.11 Export Power Set | 33 |
| 6.5.12 Restart HMI | 37 |
| 6.5.13 Debug Parameter | 37 |
| 6.5.14 DSP Update | 37 |
| 6.5.15 Power Parameter | 37 |
| 7. Maintenance | 38 |
| 8. Troubleshooting | 38 |
| 9. Specifications | 41 |

1. Introduction

1.1 Product Description

Canadian Solar 4G single phase inverters integrate DRM and backflow power control function, that could suitable for smart grid requirement.

Single phase 4G series inverter contain 2 models which are listed below:
CSI-4KTL1P-GI, CSI-5KTL1P-GI

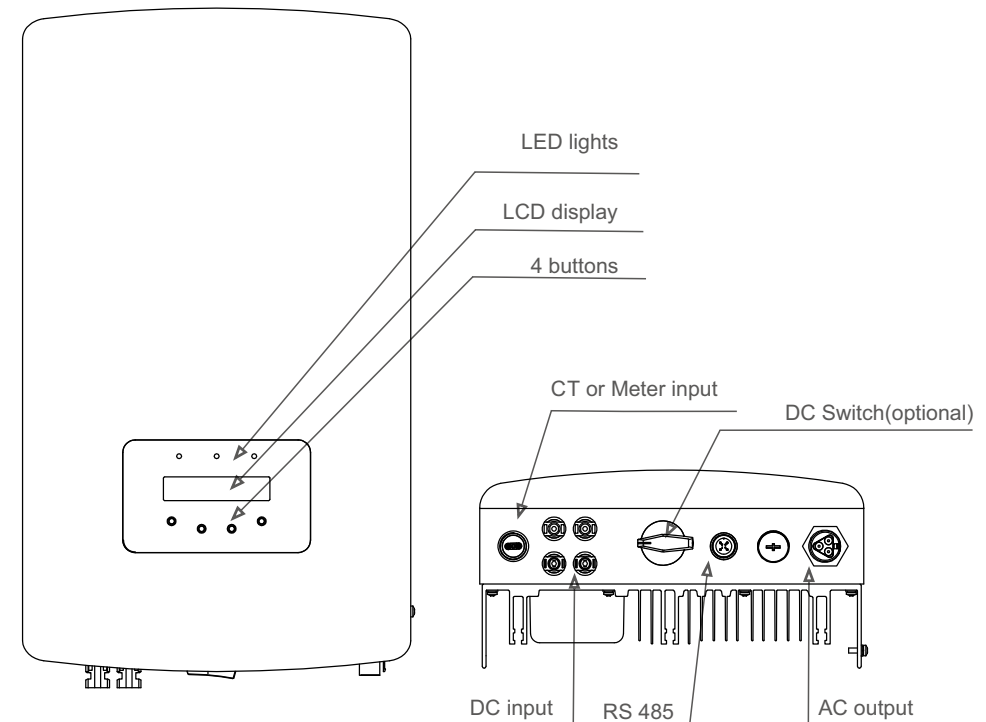

▲ Figure 1.1 Front side view

▲ Figure 1.2 Bottom side view

1. Introduction

2. Safety Instructions

1.2 Packaging

When you receive the inverter, ensure that all the parts listed below are included:

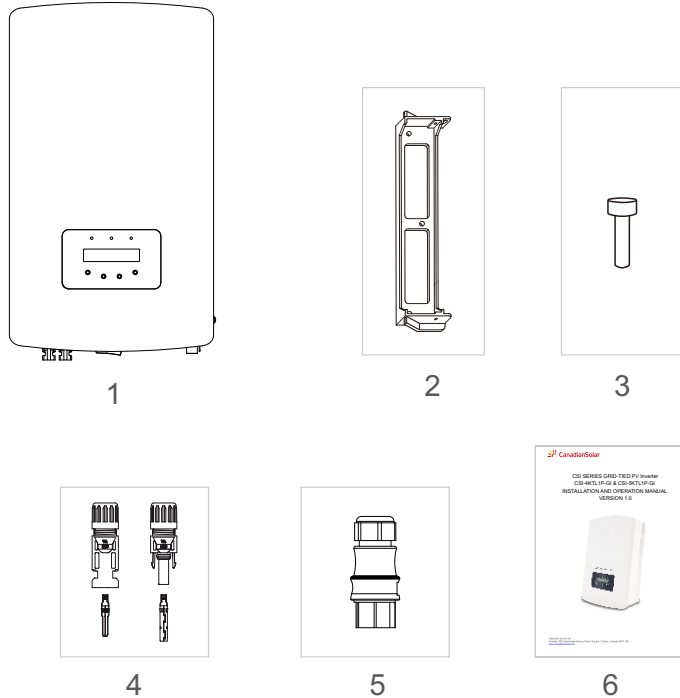

| Part # | Description | Number |
|--------|----------------------|---------|
| 1 | PV grid tie inverter | 1 |
| 2 | Wall/pole bracket | 1 |
| 3 | Locking screws | 2 |
| 4 | DC connector | 2 pairs |
| 5 | AC connector | 1 |
| 6 | Manual | 1 |

▲ Table 1.1 Parts list

Improper use may result in potential electric shock hazards or burns. This manual contains important instructions that should be followed during installation and maintenance. Please read these instructions carefully before use and keep them for future reference.

2.1 Safety Symbols

Safety symbols used in this manual, which highlight potential safety risks and important safety information, are listed as follows:



WARNING:

WARNING symbol indicates important safety instructions, which if not correctly followed, could result in serious injury or death.



NOTE:

NOTE symbol indicates important safety instructions, which if not correctly followed, could result in some damage or the destruction of the inverter.



CAUTION:

CAUTION, RISK OF ELECTRIC SHOCK symbol indicates important safety instructions, which if not correctly followed, could result in electric shock.



CAUTION:

CAUTION, HOT SURFACE symbol indicates safety instructions, which if not correctly followed, could result in burns.

2.2 General Safety Instructions



WARNING:

Only devices in compliance with SELV (EN 69050) may be connected to the RS485 and USB interfaces.



WARNING:

Please don't connect PV array positive(+) or negative(-) to ground, it could cause serious damage to the inverter.



WARNING:

Electrical installations must be done in accordance with the local and national electrical safety standards.



WARNING:

Do not touch any inner live parts until 5 minutes after disconnection from the utility grid and the PV input.



2. Safety Instructions



WARNING:

To reduce the risk of fire, over-current protective devices (OCPD) are required for circuits connected to the Inverter. The DC OCPD shall be installed per local requirements. All photovoltaic source and output circuit conductors shall have disconnects that comply with the NEC Article 690, Part II. All Canadian Solar single phase inverters feature an integrated DC switch.



CAUTION:

Risk of electric shock. Do not remove cover. There is no user serviceable parts inside. Refer servicing to qualified and accredited service technicians.



CAUTION:

The PV array (Solar panels) supplies a DC voltage when they are exposed to sunlight.



CAUTION:

Risk of electric shock from energy stored in capacitors of the Inverter. Do not remove cover for 5 minutes after disconnecting all power sources (service technician only). Warranty may be voided if the cover is removed without authorization.



CAUTION:

The surface temperature of the inverter can reach up to 75°C (167 F). To avoid risk of burns, do not touch the surface of the inverter while it's operating. Inverter must be installed out of the reach of children.



PV module used with inverter must have an IEC 61730 Class A rating.

2.3 Notice For Use

The inverter has been constructed according to the applicable safety and technical guidelines. Use the inverter in installations that meet the following specifications ONLY:

1. Permanent installation is required.
2. The electrical installation must meet all the applicable regulations and standards.
3. The inverter must be installed according to the instructions stated in this manual.
4. The inverter must be installed according to the correct technical specifications.
5. To startup the inverter, the Grid Supply Main Switch (AC) must be switched on, before the solar panel's DC isolator shall be switched on. To stop the inverter, the Grid Supply Main Switch (AC) must be switched off before the solar panel's DC isolator shall be switched off.

3. Overview

3.1 Front Panel Display

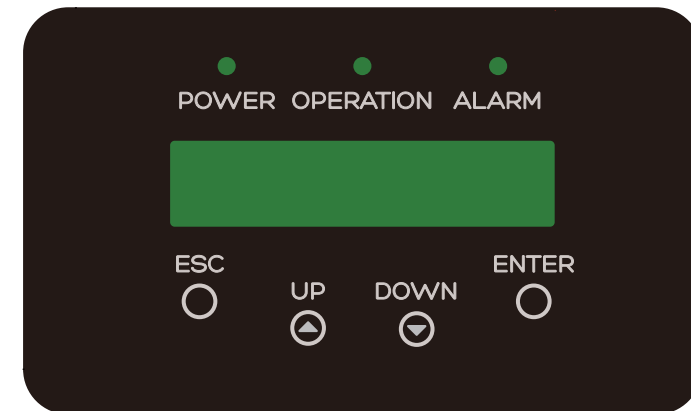

▲ Figure 3.1 Front Panel Display

3.2 LED Status Indicator Lights

There are three LED status indicator lights in the front panel of the inverter. Left LED: POWER LED (red) indicates the power status of the inverter. Middle LED: OPERATION LED (green) indicates the operation status. Right LED: ALARM LED (yellow) indicates the alarm status. Please see Table 3.1 for details

| Light | Status | Description |
|-------------|----------|---|
| ● POWER | ON | The inverter can detect DC power |
| | OFF | No DC power or low DC power |
| ● OPERATION | ON | The inverter is operating properly. |
| | OFF | The inverter has stopped to supply power. |
| | FLASHING | The inverter is initializing. |
| ● ALARM | ON | Alarm or fault condition is detected. |
| | OFF | The inverter is operating without fault or alarm. |

▲ Table 3.1 Status Indicator Lights

3. Overview

3.3 Keypad

There are four keys in the front panel of the Inverter(from left to right): ESC, UP, DOWN and ENTER keys. The keypad is used for:

- Scrolling through the displayed options (the UP and DOWN keys);
- Access to modify the adjustable settings (the ESC and ENTER keys).

3.4 LCD

The two-line Liquid Crystal Display (LCD) is located on the front panel of the Inverter, which shows the following information:

- Inverter operation status and data;
- Service messages for operator;
- Alarm messages and fault indications.

4. Installation

4.1 Select a Location for the Inverter

To select a location for the inverter, the following criteria should be considered:

- Do not install in small closed spaces where air can not circulate freely. To avoid overheating, always make sure the flow of air around the inverter is not blocked.
- Exposure to direct sunlight will increase the operational temperature of the inverter and may cause output power limiting. Canadian Solar recommends inverter installed to avoid direct sunlight or raining.
- To avoid over heating ambient air temperature must be considered when choosing the inverter installation location. Canadian Solar recommends using a sun shade minimizing direct sunlight when the ambient air temperature around the unit exceeds 104°F/40°C.

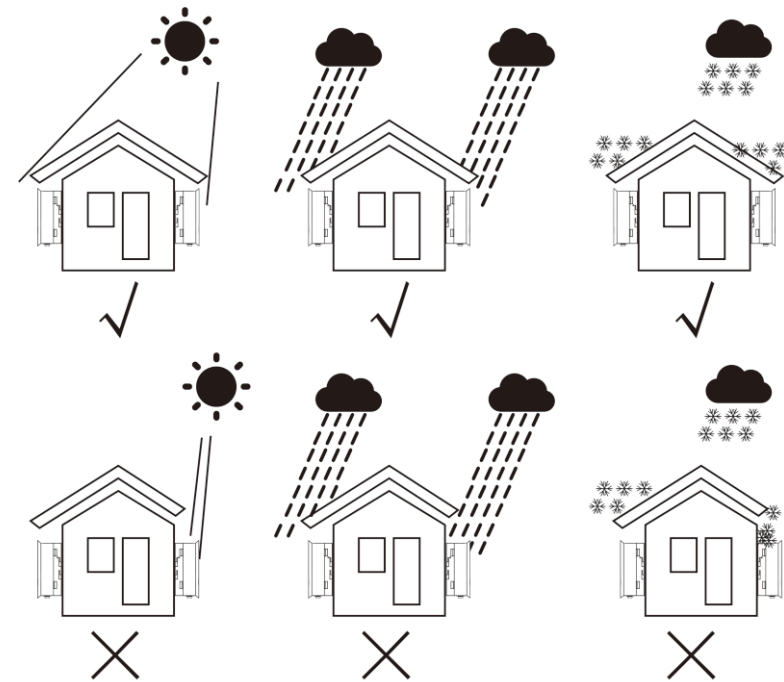

▲ Figure 4.1 Recommended Installation Locations

4. Installation

- Install on a wall or strong structure capable of bearing the weight.
- Install vertically with a maximum incline of $\pm 5^\circ$. If the mounted inverter is tilted to an angle greater than the maximum noted, heat dissipation can be inhibited, and may result in less than expected output power.
- When 1 or more inverters are installed in one location, a minimum 12 inches clearance should be kept between each inverter or other object. The bottom of the inverter should be 20 inches clearance to the ground.

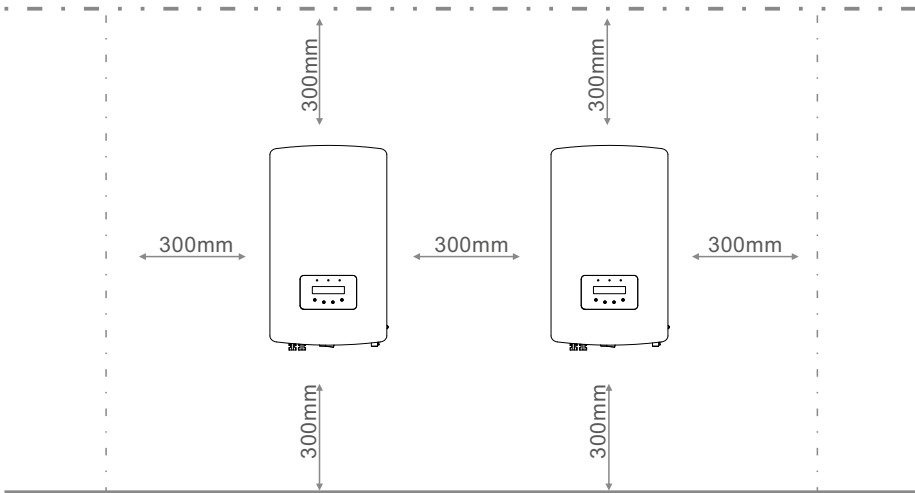

▲ Figure 4.2 Inverter Mounting clearance

- Visibility of the LED status indicator lights and the LCD located at the front panel of the inverter should be considered.
- Adequate ventilation must be provided if the inverter is to be installed in a confined space.



NOTE:

Nothing should be stored on or placed against the inverter.

4. Installation

4.2 Mounting the Inverter

Dimensions of wall bracket:

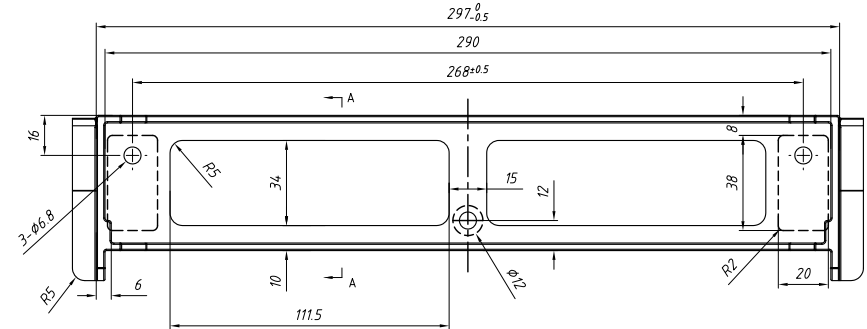

▲ Figure 4.3 Inverter wall mounting

Please see Figure 4.4 and Figure 4.5 for instruction on mounting the inverter.

The inverter shall be mounted vertically. The steps to mount the inverter are listed below:

1. According to the figure 4.2, select the mounting height of the bracket and mark the mounting holes. For brick walls, the position of the holes should be suitable for the expansion bolts.

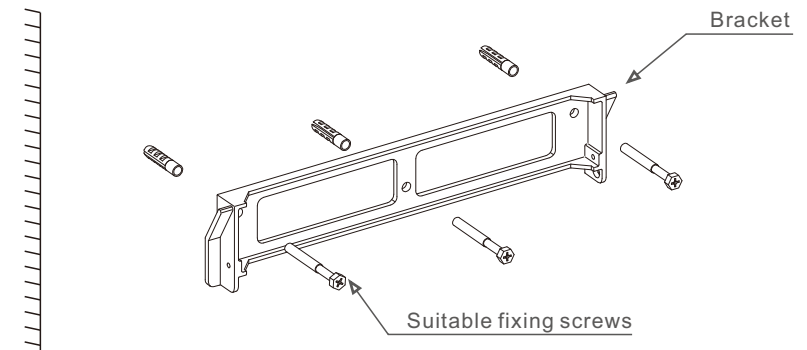

▲ Figure 4.4 Inverter wall mounting

4. Installation

- 2. Make sure the bracket is horizontal and the mounting holes (in Figure 4.4) are marked correctly. Drill the holes into the wall or pillar at your marks.
- 3. Use the suitable screws to fix the bracket to the wall.



WARNING:

The inverter must be mounted vertically.

- 4. Lift up the inverter (be careful to avoid body strain), and align the back bracket on the inverter with the convex section of the mounting bracket. Hang the inverter on the mounting bracket and make sure the inverter is secure (see Figure 4.5).

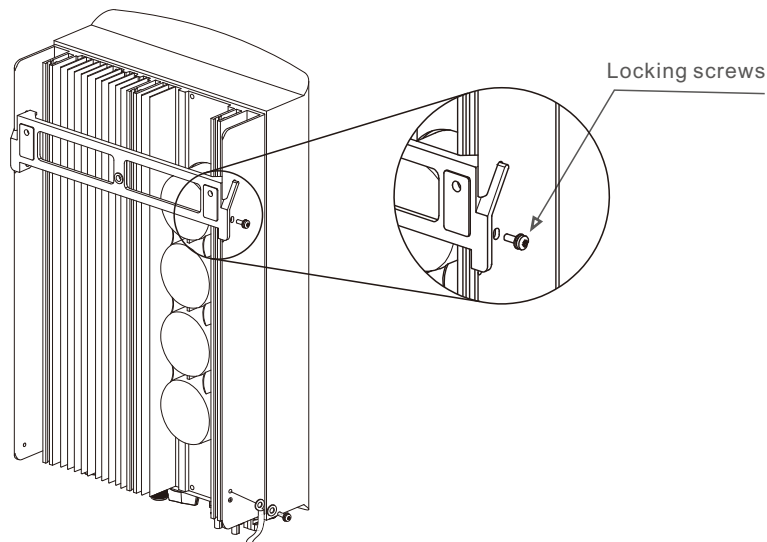

▲ Figure 4.5 Wall Mount Bracket

- 5. Use M4*9 screws in accessory to lock the inverter to the mount bracket.

4. Installation

4.3 Electrical Connections

4.3.1 Connect PV side of inverter

The electrical connection of the inverter must follow the steps listed below:

- 1. Switch the Grid Supply Main Switch (AC) OFF.
- 2. Switch the DC Isolator OFF.
- 3. Assemble PV input connector to the Inverter.



Before connecting inverter, please make sure the PV array open circuit voltage is within the limit of the inverter

Maximum 600Voc for
CSI-4KTL1P-GI CSI-5KTL1P-GI



Please don't connect PV array positive or negative pole to the ground, it could cause serious damages to the inverter.



Before connection, please make sure the polarity of the output voltage of PV array matches the "DC+" and "DC-" symbols.

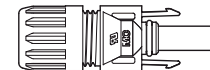

▲ Figure 4.6 DC+ Connector

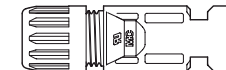

▲ Figure 4.7 DC- Connector

4. Installation

4. Installation



Please use approved DC cable for PV system.

| Cable type | Cross section | |
|--|-----------------------|-------------------|
| | Range | Recommended value |
| Industry generic PV cable (model:PV1-F) | 4.0~6.0 (12~10AWG) | 4.0 (12AWG) |

▲ Table 4.1 DC cable

The steps to assemble the DC connectors are listed as follows:

i) Strip off the DC wire for about 7mm, Disassemble the connector cap nut.

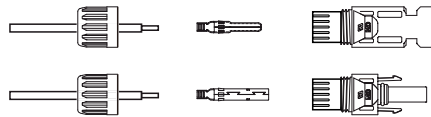

▲ Figure 4.8 Disassemble the Connector Cap nut

ii) Insert the wire into the connector cap nut and contact pin.

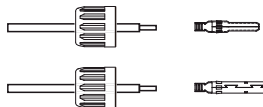

▲ Figure 4.9 Insert the Wire into the Connector Cap nut and contact pin

iii) Crimp the contact pin to the wire using a proper wire crimper.

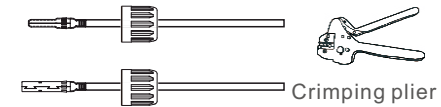

▲ Figure 4.10 Crimp the contact pin to the wire

iv) Insert the contact pin to the top part of the connector and screw up the cap nut to the top part of the connector.

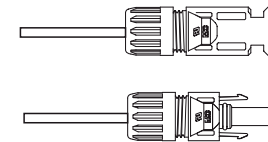

▲ Figure 4.11 Connector with Cap nut Screwed on

v) Then connect the DC connectors to the inverter. Small click will confirm connection.

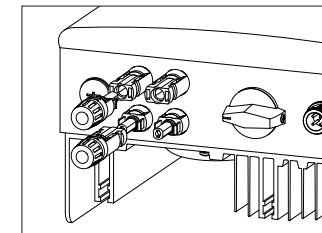

▲ Figure 4.12 Connect the DC Connectors to the Inverter

4. Installation

4. Installation

4.3.2 Connect grid side of inverter

For all AC connections, 2.5- 6mm² 105 °C cable is required to be used. Please make sure the resistance of cable is lower than 1 ohm. If the wire is longer than 20m, it's recommended to use 6mm² cable.



WARNING:

There are “L” “N” “⏏” symbols marked inside the connector , the Line wire of grid must be connected to “L” terminal; the Neutral wire of grid must be connected to “N” terminal; the Earth of grid must be connected to “⏏” (see Figure 4.13).

| Cable type | Cross section | |
|-----------------------------|------------------------|-------------------|
| | Range | Recommended value |
| Industry generic grid cable | 2.5~6.0mm ² | 6mm ² |

▲ Table 4.2 Grid cable size



▲ Figure 4.13 AC Grid Terminal Connector Inside

Each Canadian Solar Single Phase Inverter is supplied with an AC grid terminal connector.



▲ Figure 4.14 AC Grid Terminal Connector

The steps to assemble the AC grid terminal connectors are listed as follows:

- a) Disassemble the AC connector. Strip the AC wires about 6mm.

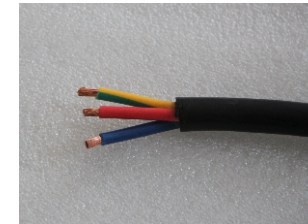

▲ Figure 4.15 Stripped AC Wires

- b) Fix the green and yellow wire to the ground terminal. Fix the red(or brown) wire to L (line) terminal. Fix the blue wire to N(Neutral). Tight the screws on the connector. Please try to pull out the wire to make sure the it's well connected.

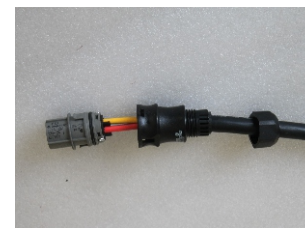

▲ Figure 4.16 Connect Wires to the Terminal

- c) Tighten up the cap on the terminal (see Figure 4.17).

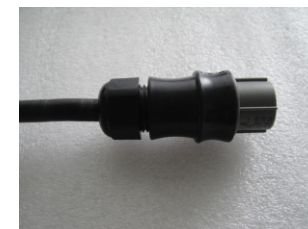

▲ Figure 4.17 Tighten up the Cap on the Terminal

4. Installation

d) Connect the AC grid terminal connector to the inverter. Small click will confirm connection.

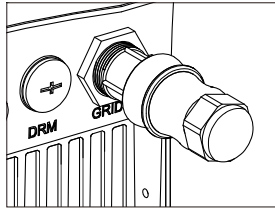

▲ Figure 4.18 Connect the AC Connector to the Inverter



Note: Connection for Split phase grid.

When connect to 208/220/240V split phase, please connect L1 to “L” terminal, L2 to “N” terminal. Also connect earth to ground terminal.

4.3.3 External ground connection

An external ground connection is provided at the right side of inverter. Prepare OT terminals: M4. Use proper tooling to crimp the lug to the terminal. Connect the OT terminal with ground cable to the right side of inverter. The torque is 20 in-lbs (2Nm).

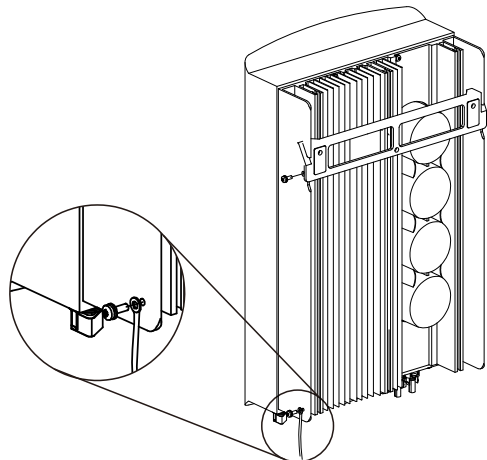

▲ Figure 4.19 Connect the external grounding conductor

4. Installation

4.3.4 Max. over current protection device (OCPD)

To protect the inverter's AC grid connection conductors, Canadian Solar recommends installing breakers that will protect against overcurrent. The following table defines OCPD ratings for the Canadian Solar 4-5kW single phase inverters.

| Inverter | Rated output voltage(V) | Rated output current (A) | Current for protection device (A) |
|---------------|-------------------------|--------------------------|-----------------------------------|
| CSI-4KTL1P-GI | 220/230 | 18.2/17.4 | 25 |
| CSI-5KTL1P-GI | 220/230 | 22.7/21.7 | 30 |

▲ Table 4.3 Rating of grid OCPD

4.3.5 Inverter monitoring connection

The inverter can be monitored via Wi-Fi or GPRS. All Canadian Solar communication devices are optional (Figure 4.20). For connection instructions, please refer to the Canadian Solar Monitoring Device installation manuals.

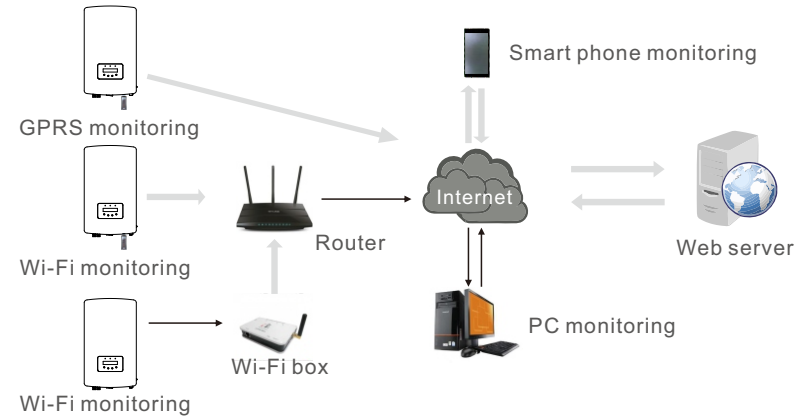

▲ Figure4.20 Wi-Fi or GPRS communication function

4. Installation

4. Installation

4.3.6 Electrical connection diagram

Refer to figure 4.21, which is a simple guidance for installing a solar system with PV inverter. A DC isolator is required to be installed in the system between PV panels with inverter.

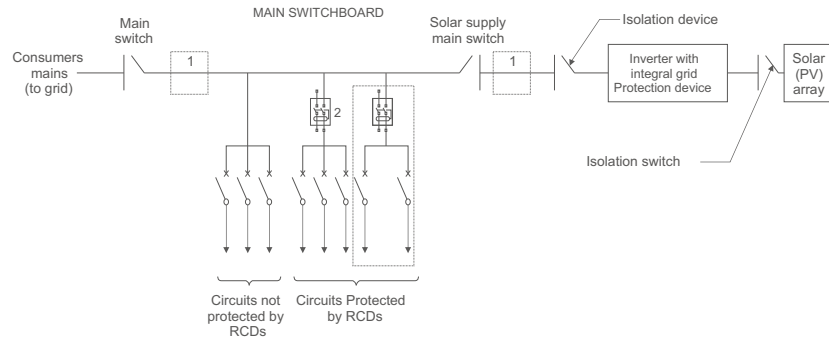

▲ Figure 4.21 Guidance for a Simple Installation of an Inverter Solar Energy System

1. The RCD should be in parallel connection between the consumers mains and the solar supply.
2. More than one RCD may be used. Each RCD can protect one or more circuits.

4.3.7 Meter Connection(optional)

The inverter has intergrated export limitation functionality. To use this function, a power meter or a CT must be installed, if use the power meter, it should be installed in the load side or in the grid side, Because the meter used in the single-phase inverter is divided into two types: single-direction meter, and dual-direction meter. Therefore, the wiring method is divided into two cases. The dual-direction meter corresponds to the meter in grid connection mode; the single-direction meter corresponds to the meter in load connection mode. see Figure 4.22 and 4.23. After the inverter power on, please set the corresponding configuration as sections 6.5.11.1.2 and 6.5.11.1.3.

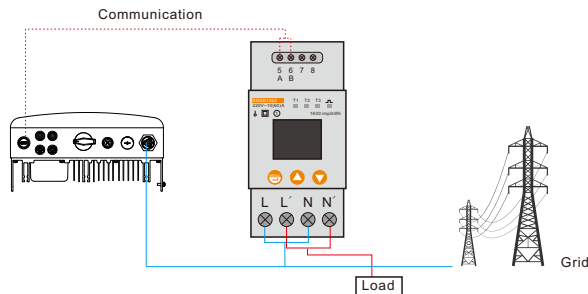

▲ Figure 4.22 Meter in Load

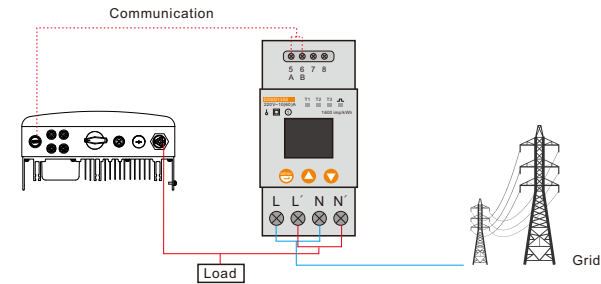

▲ Figure 4.23 Meter in Grid

4.3.8 CT connections(optional)

This inverter has integrated export limitation functionality. To use this function, a power meter or a CT must be installed, if use the CT, please reference below picture. The CT should be fitted around the live conductor on the grid side of the main incoming consumer unit. Use the directional flow indication arrow on the CT to ensure it is fitted in the correct orientation. The arrow should be pointing towards the grid, not the load. when the inverter power on, please set the corresponding configuration as sections 6.5.11.1.4.1 and 6.5.11.1.4.2.

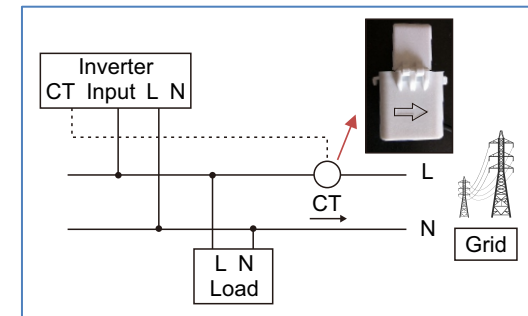

▲ Figure 4.24 Direction of CT

4. Installation

5. Start & Stop

4.3.9 Logic interface connection (Only for UK)

Logic interface is required by G98 and G99 standard that can be operated by a simple switch or contactor. When the switch is closed the inverter can operated normally. When the switch is opened, the inverter will reduce it's output power to zero within 5s.

Pin5 and Pin6 of RJ45 terminal is used for the logic interface connection.

Please follow below steps to assemble RJ45 connector.

1. Insert the network cable into the communication connection terminal of RJ45.
(As shown in figure 4.25)



▲ Figure 4.25 RJ45 communication connection terminals

2. Use the network wire stripper to strip the insulation layer of the communication cable. According to the standard line sequence of figure 4.26 connect the wire to the plug of RJ45, and then use a network cable crimping tool to make it tight.

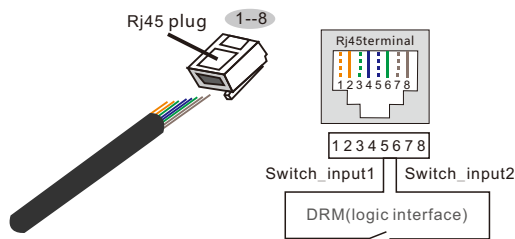

▲ Figure 4.26 Strip the insulation layer and connect to RJ45 plug

3. Connect RJ45 to DRM (logic interface) .

After wire connection, please refer chapter 6.5.8.1 to enable the logic interface function.

5.1 Start the Inverter

To start up the Inverter, it is important that the following steps are strictly followed:

1. Switch the grid supply main Switch (AC) ON first.
2. Switch the DC switch ON. If the voltage of PV arrays are higher than start up voltage, the inverter will turn on. The red LED power will light.
3. When both the DC and the AC sides supply to the inverter, it will be ready to generate power. Initially, the inverter will check both its internal parameters and the parameters of the AC grid, to ensure that they are within the acceptable limits. At the same time, the green LED will flash and the LCD displays the information of INITIALIZING.
4. After 30-300 seconds (depending on local requirement), the inverter will start to generate power. The green LED will be on continually and the LCD displays GENERATING.



WARNING:

Do not touch the surface when the inverter is operating. It may be hot and cause burns.

5.1.1 Inverter working status

When inverter working normally, there would be 5 status :

- Generating: Inverter is working normally
- LimByTemp: Inverter power limited by over ambient temperature.
- LimByFreq: Inverter power limited by over grid frequency
- LimByVg: Inverter power limited by over grid voltage
- LimByVar: Inverter power limited by generating reactive power.

5.2 Stop the Inverter

To stop the Inverter, the following steps must be strictly followed:

1. Switch the Supply Main Switch (AC) OFF.
2. Wait 30 seconds. Switch the DC Switch OFF. All the LEDs of the inverter will be off in one minute.

6. Operation

6. Operation

During normal operation, the display alternately shows the power and the operation status with each screen lasting for 10 seconds (see Figure 6.1). Screens can also be scrolled manually by pressing the UP and DOWN keys. Press the ENTER key to access to the Main Menu.

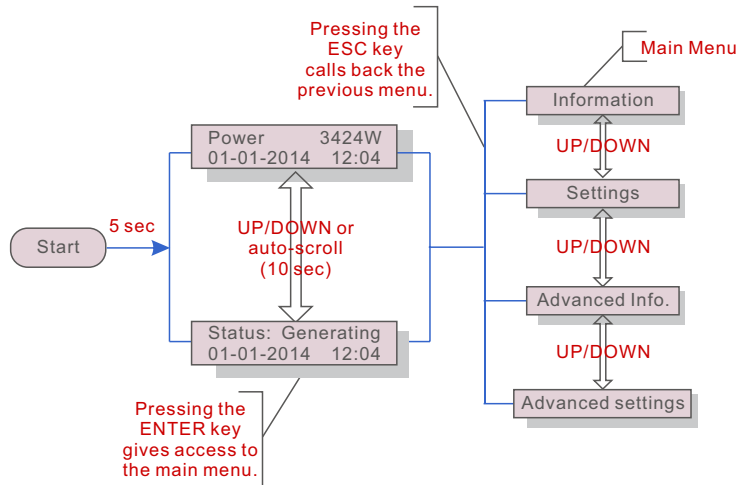

▲ Figure 6.1 Operation Overview

6.1 Main Menu

There are four submenus in the Main Menu (see Figure 6.1):

1. Information
2. Settings
3. Advanced Info.
4. Advanced Settings

6.2 Information

The Canadian Solar Single Phase 4G Inverter main menu provides access to operational data and information. The information is displayed by selecting "Information" from the menu and then by scrolling up or down.

| Display | Duration | Description |
|--|----------|--|
| V_DC1 350.8V I_DC1 5.1A | 10 sec | V_DC1: Shows input 01 voltage value. I_DC1: Shows input 01 current value. |
| V_DC2 350.8V I_DC2 5.1A | 10 sec | V_DC2: Shows input 02 voltage value. I_DC2: Shows input 02 current value. |
| V_Grid 230.4V I_Grid 8.1A | 10 sec | V_Grid: Shows the grid's voltage value I_Grid: Shows the grid's current value. |
| Status: Generating Power: 1488W | 10 sec | Status: Shows instant status of the Inverter. Power: Shows instant output power value. |
| Grid Frequency F_Grid 60.06Hz | 10 sec | F_Grid: Shows the grid's frequency value. |
| Total Energy 0258458 kWh | 10 sec | Total generated energy value. |
| This Month: 0123kwh Last Month: 0123kwh | 10 sec | This Month: Total energy generated this month. Last Month: Total energy generated last month. |
| Today: 15.1kwh Yesterday: 13.5kwh | 10 sec | Today: Total energy generated today. Yesterday: Total energy generated yesterday. |
| Inverter SN 00000000000000 | 10 sec | Display series number of the inverter. |
| Export_P: +0000W Export_I: 00.0A | 10 sec | Power of ERM. Current of EPM. |
| Work Mode: NULL DRM Number: 08 | 10 sec | Work Mode: The work mode of inverter. DRM Number: Show the number 01-08. |
| Meter EnergyP 0000000.00kWh | 10 sec | Meter EnergyP: The active power. |

▲ Table 6.1 Information list

6. Operation

6. Operation

6.2.1 Lock screen

Pressing the ESC key returns to the Main Menu. Pressing the ENTER key locks (Figure 6.2(a)) or unlocks (Figure 6.2 (b)) the screen.



▲ Figure 6.2 Locks and Unlocks the Screen of LCD

6.3 Settings

The following submenus are displayed when the Settings menu is selected:

- 1.Set Time
- 2.Set Address

6.3.1 Set Time

This function allows time and date setting. When this function is selected, the LCD will display a screen as shown in Figure 6.3.



▲ Figure 6.3 Set Time

Press the UP/DOWN keys to set time and data. Press the ENTER key to move from one digit to the next (from left to right). Press the ESC key to save the settings and return to the previous menu.

6.3.2 Set Address

This function is used to set the address when muti inverters are connected to single monitor. The address number can be assigned from "01"to "99"(see Figure 6.4). The default address number of Canadian Solar Single Phase Inverter is "01".



▲ Figure 6.4 Set Address

Press the UP/DOWN keys to set the address. Press the ENTER key to save the settings. Press the ESC key to cancel the change and return to the previous menu.

6.4 Advanced Info - Technicians Only



NOTE:

To access to this area is for fully qualified and accredited technicians only. Enter menu "Advanced Info." and "Advanced settings" (need password) .

Select "Advanced Info." from the Main Menu. The screen will require the password as below



▲ Figure 6.5 Enter password

The default password is "0010". Please press "down" to move the cursor, press "up" to select the number.

After enter the correct password the Main Menu will display a screen and be able to access to the following information.

- 1.Alarm Message**
- 2. Running Message**
- 3.Version**
- 4. Daily Energy**
- 5. Monthly Energy**
- 6. Yearly Energy**
- 7. Daily Record**
- 8.Communication Data**
- 9. Warning Message**

The screen can be scrolled manually by pressing the UP/DOWN keys. Pressing the ENTER key gives access to a submenu. Press the ESC key to return to the Main Menu.

6.4.1 Alarm Message

The display shows the 100 latest alarm messages (see Figure 6.6). Screens can be scrolled manually by pressing the UP/ DOWN keys. Press the ESC key to return to the previous menu.



▲ Figure 6.6 Alarm Message

6. Operation

6. Operation

6.4.2 Running Message

This function is for maintenance person to get running message such as internal temperature, Standard NO. etc.

Screens can be scrolled manually by pressing the UP/DOWN keys.

6.4.3 Version

The screen shows the model version and the software version of the Inverter (see Figure 6.7).



Model: 08
Software Version: D20001

▲ Figure 6.7 Model Version and Software Version

6.4.4 Daily Energy

The function is for checking the energy generation for selected day.



YES=<ENT> NO=<ESC>
Select: 2015-02-23

▲ Figure 6.8 Select date for daily energy

Press DOWN key to move the cursor to day, month and year, press UP key to change the digit. Press Enter after the date is fixed.

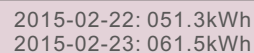

2015-02-22: 051.3kWh
2015-02-23: 061.5kWh

▲ Figure 6.9 Daily energy

Press UP/DOWN key to move one date from another.

6.4.5 Monthly Energy and Yearly Energy

The two functions are for checking the energy generation for selected month and Year



YES=<ENT> NO=<ESC>
Select: 2015-02



YES=<ENT> NO=<ESC>
Select: 2015

▲ Figure 6.10 Select month for monthly energy ▲ Figure 6.11 Select year for yearly energy

Press DOWN key to move the cursor, press UP key to change the digit.

Press Enter after the month/year is fixed.

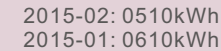

2015-02: 0510kWh
2015-01: 0610kWh

▲ Figure 6.12 Month energy



2015: 0017513kWh
2014: 0165879kWh

▲ Figure 6.13 Yearly energy

Press UP/DOWN key to move one date from another.

6.4.6 Daily record

The screen shows history of changing settings. Only for maintenance personnel.

6.4.7 Communication Data

The screen shows the internal data of the Inverter (see Figure 6.14), which is for service technicians only.

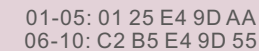

01-05: 01 25 E4 9D AA
06-10: C2 B5 E4 9D 55

▲ Figure 6.14 Communication Data

6.4.8 Warning Message

The display shows the 100 latest warn messages (see Figure 6.15). Screens can be scrolled manually by pressing the UP/ DOWN keys. Press the ESC key to return to the previous menu.

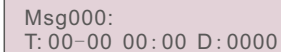

Msg000:
T: 00-00 00:00 D: 0000

▲ Figure 6.15 Warning Message

6.5 Advanced Settings - Technicians Only



NOTE:

To access to this area is for fully qualified and accredited technicians only. Please follow 6.4 to enter password to access this menu.

Select Advanced Settings from the Main Menu to access the following options:

1. Select Standard
2. Grid ON/OFF
3. Clear Energy
4. Reset Password
5. Power Control
6. Calibrate Energy
7. Special Settings
8. STD. Mode Settings
9. Restore Settings
10. HMI Update
11. Export Power Set
12. Restart HMI
13. Debug Parameter
14. DSP Update
15. Power Parameter

6. Operation

6. Operation

6.5.1 Selecting Standard

This function is used to select the grid's reference standard (see Figure 6.16).

YES=<ENT> NO=<ESC>
Standard:AS4777-02

▲ Figure 6.16

Press the UP/DOWN keys to select the standard (AS4777-02,AS4777-15, VDE4105, VDE0126, UL-240V-A, UL-208V-A, UL-240V, UL-208V, MEX-CFE, G83/2 (for 1-3.6kW models), G59/3 (for 4-5kW models), EN50438 DK, EN50438 IE, EN50438 NL and "User-Def" function).

Press the ENTER key to confirm the setting. Press the ESC key to cancel changes and returns to previous menu.



NOTE:

This function is for technicians use only.

Selecting the "User-Def" menu will access to the following submenu (see Figure 6.17),

– OV-G-V1: 260V
OV-G-V1-T: 1S

▲ Figure 6.17



NOTE:

The "User-Def" function can be only used by the service engineer and must be allowed by the local energy supplier.

Below is the setting range for "User-Def". Using this function, the limits can be changed manually.

| | |
|---------------------|-------------------------------|
| OV-G-V1: 240---270V | OV-G-F1: 50.2-53Hz(60.2-64Hz) |
| OV-G-V1-T: 0.1---9S | OV-G-F1-T: 0.1---9S |
| OV-G-V2: 240---300V | OV-G-F2: 50.2-53Hz(60.2-64Hz) |
| OV-G-V2-T: 0.1---1S | OV-G-F2-T: 0.1---9S |
| UN-G-V1: 170---210V | UN-G-F1: 47-49.5Hz(56-59.8Hz) |
| UN-G-V1-T: 0.1---9S | UN-G-F1-T: 0.1---9S |
| UN-G-V2: 110---210V | UN-G-F2: 47-49Hz(56-59.8Hz) |
| UN-G-V2-T: 0.1---1S | UN-G-F2-T: 0.1---9S |
| Startup-T: 10-600S | Restore-T: 10-600S |

Press the UP/DOWN keys to scroll through items. Press the ENTER key to edit the highlighted item. Press the UP/DOWN keys again to change the setting. Press the ENTER key to save the setting. Press the ESC key to cancel changes and returns to the previous menu.

6.5.2 Grid ON/OFF

This function is used to start up or stop the power generation of Canadian Solar Single Phase Inverter (see Figure 6.18).

– Grid ON
Grid OFF

▲ Figure 6.18 Set Grid ON/OFF

Screens can be scrolled manually by pressing the UP/DOWN keys. Press the ENTER key to save the setting. Press the ESC key to return to the previous menu.

6.5.3 Clear Energy

Clear Energy can reset the history yield of inverter



These two functions are applicable by maintenance personnel only, wrong operation will prevent the inverter from working properly.

6.5.4 Reset Password

This function is used to set the new password for menu "Advanced info." and "Advanced information" (see Figure 6.19).

YES=<ENT> NO=<ESC>
Password: 0000

▲ Figure 6.19 Reset password

Enter the right password before set new password. Press the DOWN key to move the cursor, Press the UP key to revise the value. Press the ENTER key to execute the setting. Press the ESC key to return to the previous menu.

6.5.5 Power Control

Active and reactive power can be set through power setting button.

There are 5 item for this sub menu:

1. Set output power
2. Set Reactive Power
3. Out_P With Restore
4. Rea_P With Restore
5. Select PF Curve



This function is applicable by maintenance personnel only, wrong operation will prevent the inverter from reaching maximum power.

6. Operation

6. Operation

6.5.6 Calibrate Energy

Maintenance or replacement could clear or cause a different value of total energy. Use this function could allow user to revise the value of total energy to the same value as before. If the monitoring website is used the data will be synchronous with this setting automatically. (see Figure 6.20).

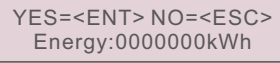

```
YES=<ENT> NO=<ESC>
Energy:0000000kWh
```

▲ Figure 6.20 Calibrate energy

Press the DOWN key to move the cursor, Press the UP key to revise the value. Press the ENTER key to execute the setting. Press the ESC key to return to the previous menu.

6.5.7 Special Settings



This function is applicable by maintenance personnel only, wrong operation will prevent the inverter from working properly.

6.5.8 STD. Mode Settings

There are 5 setting under STD. Mode settings.

1. Working mode
2. Power Rate limit
3. Freq. Derate set
4. 10mins OV-G-V set.
5. Initial Settings



This function is applicable by maintenance personnel only, wrong operation will prevent the inverter from working properly.

6.5.8.1 Enable logic interface settings

When select G98 or G99 standard to use the logic interface function, please follow below settings to enable the **DRM**. DRM default setting is "OFF", if DRM set "ON", but the logic interface un-connected to the switch or the switch is open, the inverter HMI will display "Limit by DRM" and the inverter output power will be limited to zero.

1. Select **Initial Settings**
2. Select **DRM** and set it "ON"

6.5.9 Restore Settings

Restore setting could set all item in 6.5.7 special setting to default. The screen shows as below:



```
Are you sure?
YES=<ENT> NO=<ESC>
```

▲ Figure 6.21 Restore Settings

Press the Enter key to save the setting after setting grid off.

Press the ESC key to return the previous menu.

6.5.10 HMI Update

This function is used for update the LCD program.



This function is applicable by maintenance personnel only, wrong operation will prevent the inverter from reaching maximum power.

6.5.11 Export Power Set



NOTE:

To access to this area is for fully qualified and accredited technicians only. Please follow 6.4 to enter password to access this menu.

The default password is "0010". Please press "down" to move the cursor, press "up" to select the number.

Select EPM Settings from the Main Menu to access the following options:

1. Model Select
2. Set Backflow Power
3. Fail safe ON/OFF

6. Operation

6. Operation

6.5.11.1 Model Select

There are 4 settings in this menu as below:

1.OFF 2.Meter in Load 3.Meter in Grid 4.Current sensor

6.5.11.1.1 OFF

This function is used to shut down the Export Power Set.

ON=<ENT> CANCEL=<ESC>
OFF

▲ Figure 6.22

Press the ENTER key to set done.

Press the ESC key to the previous menu.

6.5.11.1.2 Meter in Load

The submenu is used to set meter in Load as shown as 4.3.7 Meter connection(optional).

ON=<ENT> CANCEL=<ESC>
Meter in Load

▲ Figure 6.23

Press Enter key to save the setting.

6.5.11.1.3 Meter in Grid

The submenu is used to set meter in Grid as shown as 4.3.7 Meter connection(optional).

ON=<ENT> CANCEL=<ESC>
Meter in Grid

▲ Figure 6.24

Press Enter key to save the setting.

6.5.11.1.4 Current sensor

The submenu is used to set current sensor as shown as 4.3.8 CT connection(optional).

There are 2 modes shown as below: 1.CT Sampling Ratio 2.CT Link test

ON=<ENT> CANCEL=<ESC>
Current Sensor

▲ Figure 6.25

6.5.11.1.4.1 CT Sampling Ratio

This function is used for change CT Sampling Ratio if customer select different CT.

The default ratio is 3000:1.

-> CT Sampling Ratio

▲ Figure 6.26 Set the CT Para of the EPM

YES=<ENT> NO=<ESC>
Ratio:3000:1

▲ Figure 6.27

Press the UP/DOWN keys to set data.Press the ENTER key to set CT Para.

Press the ESC key to save the settings and return to the previous menu.

6.5.11.1.4.2 CT Link Test

Before pressing the CT Link Test menu, please check as follow:

- 1.Load power \geq 500W
- 2.Inverter should be set Grid Off
- 3.CT should be connected
- 4.EPM should be set ON

Press the ENTER key to show the screen of CT Link Test .it will show as below when the EPM was set ON :

CT Link State
Correct

▲ Figure 6.28 CT Link State

Press the ESC key to the previous menu.



NOTE:

There are three states in the CT Link State.

“Error” means CT reverse connection. Please change CT direction

“Can not judge” means load power is not enough, it should be more than 500W.

“Correct” means CT has been connected correctly.

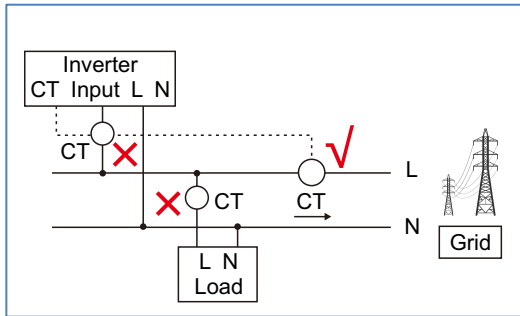

▲ Figure 6.29 CT location



See figure 6.29. If CT test pass but inverter still can't achieve export power (power is not controllable or always 0 power output). Please check installation location of the CT.

6.5.11.2 Backflow Power

This submenu is used for set allowed power that inverter can generate to grid .

->Set Backflow Power

▲ Figure 6.30 Set the backflow power

YES=<ENT> NO=<ESC>
P_Backflow:-0001W

▲ Figure 6.31

Press the UP/DOWN keys to set data. Press the ENTER key to set backflow power. Then press DOWN keys to move the cursor, press UP to change the number. Press the ESC key to save the settings and return to the previous menu.

6.5.11.3 Fail safe ON/OFF

This function is used to remind whether the fail safe function is ON or not. The default setting is ON.

YES=<ENT> NO=<ESC>
Fail Safe Set:ON

▲ Figure 6.32 Set the Fail Safe ON/OFF

Press the UP/DOWN keys to set ON/OFF. Press the ENTER key to set done . Press the ESC key to the previous menu.

ON: When CT is disconnected, the inverter will stop generate power and LCD show "Fail Safe"
OFF: When CT is disconnected, the inverter will be limited to the power at the time CT is disconnected. If restart, inverter will not limit output power.

6.5.12 Restart HMI

The function is used for restart the HMI.



This function is applicable by maintenance personnel only, wrong operation will prevent the inverter from reaching maximum power.

6.5.13 Debug Parameter

This function is used for manufacturer maintenance personnel only.

6.5.14 DSP Update

The function is used for update the DSP.



This function is applicable by maintenance personnel only, wrong operation will prevent the inverter from reaching maximum power.

6.5.15 Power Parameter

This function is used for calibrate inverter output energy. It will not impact the energy count for inverter with RGM.
The screen shows:

YES=<ENT> NO=<ESC>
Power para: 1. 000

▲ Figure 6.33 Power Rate Limit

Press the Down key to move the cursor.
Press the Up key to change the digit.
Please press the Enter to save the setting and press the ESC key to return to the previous menu.



This setting is used for grid operator, don't change setting under this manual.

7. Maintenance

7. Maintenance

Canadian Solar Single Phase 4G Inverter does not require any regular maintenance. However, cleaning the dust on heat-sink will help the inverter to dissipate the heat and increase its life time. The dust can be removed with a soft brush.



CAUTION:

Do not touch the inverter's surface when it is operating. Some parts of the inverter may be hot and cause burns. Turn off the inverter (refer to Section 5.2) and wait for a cool-down period before any maintenance or cleaning operation.

The LCD and the LED status indicator lights can be cleaned with a damp cloth if they are too dirty to be read.



NOTE:

Never use any solvents, abrasives or corrosive materials to clean the inverter.

8. Troubleshooting

The inverter is designed in accordance with the most important international grid-tied standards and safety and electromagnetic compatibility requirements. Before delivering to the customer, the inverter has been subjected to several tests to ensure its optimal operation and reliability.

In case of failure, the LCD screen will display an alarm message. In this case, the inverter may stop feeding into the grid. The failure descriptions and their corresponding alarm messages are listed in Table 8.1:

8. Trouble Shooting

| Alarm Message | Failure description | Solution |
|------------------------------------|--|---|
| No power | Inverter no power on LCD | 1. Check PV input connections 2. Check DC input voltage (single phase >120V, three phase >350V) 3. Check if PV+/- is reversed |
| LCD show initializing all the time | can not start-up | 1. Check if the connector on main board or power board are fixed. 2. Check if the DSP connector to power board are fixed. |
| OV-G-V01/02/03/04 | Over grid voltage | 1. Resistant of AC cable is too high. Change bigger size grid cable 2. Adjust the protection limit if it's allowed by electrical company. |
| UN-G-V01/02 | Under grid voltage | 1. Use user define function to adjust the protection limit if it's allowed by electrical company. |
| OV-G-F01/02 | Over grid frequency | |
| UN-G-F01/02 | Under grid frequency | |
| G-IMP | High grid impedance | |
| NO-GRID | No grid voltage | 1. Check connections and grid switch. 2. Check the grid voltage inside inverter terminal. |
| OV-DC01/02/03/04 | Over DC voltage | 1. Reduce the module number in series |
| OV-BUS | Over DC bus voltage | 1. Check inverter inductor connection 2. Check driver connection |
| UN-BUS01/02 | Under DC bus voltage | |
| GRID-INTF01/02 | Grid interference | 1. Restart inverter 2. Change power board |
| OV-G-I | Over grid current | |
| IGBT-OV-I | Over IGBT current | |
| DC-INTF OV-DCA-I | DC input overcurrent | 1. Restart inverter 2. Identify and remove the string to the fault MPPT 2. Change power board |
| IGFOL-F | Grid current tracking fail | 1. Restart inverter or contact installer. |
| IG-AD | Grid current sampling fail | |
| OV-TEM | Over Temperature | 1. Check inverter surrounding ventilation. 2. Check if there's sunshine direct on inverter in hot weather. |
| INI-FAULT | Initialization system fault | 1. Restart inverter or contact installer. |
| DSP-B-FAULT | Comm. failure between main and slave DSP | |
| 12Power-FAULT | 12V power supply fault | |
| PV ISO-PRO 01/02 | PV isolation protection | 1. Remove all DC input, reconnect and restart inverter one by one. 2. Identify which string cause the fault and check the isolation of the string. |

8. Trouble Shooting

| Alarm Message | Failure description | Solution |
|--------------------------|----------------------------|---|
| lLeak-PRO 01/02/03/04 | Leakage current protection | 1.Check AC and DC connection 2.Check inverter inside cable connection. |
| RelayChk-FAIL | Relay check fail | 1.Restart inverter or contact installer. |
| DCinj-FAULT | High DC injection current | 1.Restart inverter or contact installer. |

▲ Table 8.1 Fault message and description



NOTE:

If the inverter displays any alarm message as listed in Table 8.1; please turn off the inverter (refer to Section 5.2 to stop your inverter) and wait for 5 minutes before restarting it (refer to Section 5.1 to start your inverter). If the failure persists, please contact your local distributor or the service center. Please keep ready with you the following information before contacting us.

1. Serial number of Canadian Solar Single Phase Inverter;
2. The distributor/dealer of Canadian Solar Single Phase Inverter (if available);
3. Installation date.
4. The description of problem (i.e. the alarm message displayed on the LCD and the status of the LED status indicator lights. Other readings obtained from the Information submenu (refer to Section 6.2) will also be helpful.);
5. The PV array configuration (e.g. number of panels, capacity of panels, number of strings, etc.);
6. Your contact details.

9. Specifications

| Model | CSI-4KTL1P-GI |
|--|---|
| Max. DC input power (Watts) | 4600 |
| Max. DC input voltage (Volts) | 600 |
| Rated DC voltage (Volts) | 330 |
| Startup voltage (Volts) | 120 |
| MPPT voltage range (Volts) | 90...520 |
| Max. input current (Amps) | 11+11 |
| Max short circuit input current (Amps) | 17.2+17.2 |
| MPPT number/Max input strings number | 2/2 |
| Rated output power (Watts) | 4000 |
| Max. output power (Watts) | 4400 |
| Max. apparent output power (VA) | 4400 |
| Rated grid voltage (Volts) | 220/230 |
| Grid voltage range (Volts) | 160...285 |
| Rated output current (Amps) | 18.2/17.4 |
| Power Factor (at rated output power) | 0.8leading~0.8lagging |
| THDi (at rated output power) | <1.5% |
| Rated grid frequency (Hertz) | 50/60 |
| Operating frequency range (Hertz) | 47...52 or 57...62 |
| Max. efficiency | 98.1% |
| EU efficiency | 97.3% |
| MPPT efficiency | >99.5% |
| Dimensions | 310W*543H*160D (mm) |
| Weight | 11.5kg |
| Topology | Transformerless |
| Operating ambient temperature range | -25°C . . . 60°C |
| Ingress protection | IP65 |
| Noise emission (typical) | <20 dBA |
| Cooling concept | Natural convection |
| Max.operation altitude | 4000m |
| Designed lifetime | >20 years |
| Grid connection standard | En50438, G83/2, G98, G99, AS4777.2:2015, VDE0126-1-1, IEC61727, VDE N4105 |
| Operating surroundings humidity | 0...100% Condensing |
| Connention | Mc4 connector and Ip67 rated plug |
| Display | LCD, 2x20 Z. |
| Communication connections | 4 pins RS485 connector |
| Monitoring | WiFi or GPRS |
| Warranty Terms | 5 Years STD (Extendable to 20 Years) |
| Maximum inverter Backfeed Current to Array | 0 A |
| Inrush Current (peak and duration) | 8.6A@5ms |
| Maximum Output Fault Current | 51.3A |
| Maximum Output Over Current Protection | 51.3A |

9. Specifications

| Model | CSI-5KTL1P-GI |
|--|---|
| Max. DC input power (Watts) | 5800 |
| Max. DC input voltage (Volts) | 600 |
| Rated DC voltage (Volts) | 330 |
| Startup voltage (Volts) | 120 |
| MPPT voltage range (Volts) | 90...520 |
| Max. input current (Amps) | 11+11 |
| Max short circuit input current (Amps) | 17.2+17.2 |
| MPPT number/Max input strings number | 2/2 |
| Rated output power (Watts) | 5000 |
| Max. output power (Watts) | 5000 |
| Max. apparent output power (VA) | 5000 |
| Rated grid voltage (Volts) | 220/230 |
| Grid voltage range (Volts) | 160...285 |
| Rated output current (Amps) | 22.7/21.7 |
| Power Factor (at rated output power) | 0.8leading~0.8lagging |
| THDi (at rated output power) | <1.5% |
| Rated grid frequency (Hertz) | 50/60 |
| Operating frequency range (Hertz) | 47...52 or 57...62 |
| Max. efficiency | 98.1% |
| EU efficiency | 97.3% |
| MPPT efficiency | >99.5% |
| Dimensions | 310W*543H*160D (mm) |
| Weight | 11.5kg |
| Topology | Transformerless |
| Operating ambient temperature range | -25°C . . . 60°C |
| Ingress protection | IP65 |
| Noise emission (typical) | <20 dBA |
| Cooling concept | Natural convection |
| Max. operation altitude | 4000m |
| Designed lifetime | >20 years |
| Grid connection standard | En50438, G83/2, G98, G99, AS4777.2:2015, VDE0126-1-1, IEC61727, VDE N4105 |
| Operating surroundings humidity | 0...100% Condensing |
| Connention | Mc4 connector and Ip67 rated plug |
| Display | LCD, 2x20 Z. |
| Communication connections | 4 pins RS485 connector |
| Monitoring | WiFi or GPRS |
| Warranty Terms | 5 Years STD (Extendable to 20 Years) |
| Maximum inverter Backfeed Current to Array | 0 A |
| Inrush Current (peak and duration) | 8.6A@5ms |
| Maximum Output Fault Current | 51.3A |
| Maximum Output Over Current Protection | 51.3A |